



GESTRA® Continuous Blowdown Valves Reactomats

BAE 36, 36-1, 36-3,
BAE 28, 29, 210, 211, 39



Issue Date: 9/01

Blowdown Valves
PN 40–320
DN 15–50 mm
(½–2")

A3

BAE

Purpose and Application

Automatically controlled continuous blowdown to reduce blowdown wastage with a GESTRA conductivity electrode and the continuous blowdown controller. The blowdown line is automatically closed on shut-down of the boiler plant.

Application in steam boilers, evaporators or similar plants, in particular plants operated automatically, e.g. in accordance with the regulations for operation without constant supervision (TRD 604).

Design

The Reactomats BAE 36-211 and BAE 39 consist of a continuous blowdown valve and an electric actuator.

The GESTRA multi-stage nozzle or, in the case of the BAE 39, the radial stage nozzle acting as regulating and closing unit of the continuous blowdown valves is controlled by the actuator. All BAE include a sample valve for checking the boiler-water concentration. The BAE 36 has a self-tightening stuffing box.

The actuator is mounted to the blowdown valves BAE 36-211 with an angle bracket, in the case of the BAE 39 directly onto the valve yoke. A reversible synchronous motor is used as driving element for the BAE 36-211 (for the BAE 39 a three-phase motor) which, via a gear adjusts the position of the regulating lever of the BAE 36-211 or the valve spindle of the BAE 39. To operate the regulating lever by hand, the actuator can be disengaged.

Operation

The boiler water is monitored by the electrode and the continuous blowdown controller.

If the conductivity limit adjusted on the continuous blowdown controller is exceeded (e.g. increase in boiler-water density as a result of large steam consumption) the continuous blowdown valve type BAE is moved by the controller to the HIGH position (OPEN). If the density is reduced again the valve is moved back to the LOW (operating) position ensuring continuous economic blowdown. On shut-down of the boiler the valve is automatically closed (position CLOSED).

The combination of continuous blowdown valve type BAE 36-1, conductivity electrode type LRG 16-5 and continuous blowdown controller type LRR 1-9 ensures automatic control of the continuous blowdown process (three-position stepping control).

The actuator of the continuous blowdown valves is triggered by the continuous blowdown controller. It is put into operation by a single-pole change-over switch or two interlocking contactors, one for each direction of rotation. The switching off is effected by the corresponding position-controlled limit switches provided in the actuator (HIGH and CLOSED). The necessary driving power is supplied by the motor via a gear with a large transmission, requiring no maintenance.

In the case of the BAE 36-211, the power of the motor is transmitted from the gear to the regulating lever of the valve by a coupling or a fork encompassing the lever. A disc-spring

assembly inserted between fork and lever ensures a slight additional travel (overrun) of the actuator so that, in the closing position, the stage nozzle is pressed against the valve seat. The actuator can be adjusted to switch off within this additional travel provided by the spring assembly.

In the case of the BAE 39 switching off is effected by torque-controlled and position-controlled limit switches.

The position-controlled limit switches are provided with a relay contact which can be used to signal the reaching of the end positions with the aid of signalling lamps to be provided on site.

Technical Data

Continuous Blowdown Valve

Max. service pressure

BAE 36,	
BAE 36-1,	32 barg (465 psig) at 250 °C
BAE 36-3:	28 barg (405 psig) at 300 °C
BAE 28:	70 barg (1015 psig) at 250 °C
	50 barg (725 psig) at 400 °C
BAE 29:	112 barg (1625 psig) at 250 °C
	80 barg (1160 psig) at 400 °C
BAE 210:	175 barg (2540 psig) at 250 °C
	125 barg (1810 psig) at 400 °C
BAE 211:	320 barg (4640 psig) at 250 °C
	292 barg (4235 psig) at 400 °C
BAE 39:	160 barg (2320 psig) at 300 °C
	100 barg (1450 psig) at 510 °C

DN (Nominal sizes)

BAE 36, BAE 36-1:	DN 15, 20, 25, 40 mm
	(½, ¾, 1, 1½")
BAE 36-3:	DN 15, 20, 25 mm
	(½, ¾, 1")
BAE 28-211:	DN 25 mm (1")
BAE 39:	DN 50 mm (2")

Connections

BAE 36, BAE 36-1, Flanged to DIN PN 40 (BS 4504, table 40)
BAE 36-3: flanged to other standards on request

BAE 28-211: Butt-weld ends for pipe according to

DIN 2448:	30.0 x 2.6 to 4.5 mm
	31.8 x 2.6 to 5.0 mm
	33.7 x 3.6 to 6.3 mm
	38.0 x 5.6 to 8.0 mm

ANSI B 36.10: 1" Schedule 80 and 160 other dimensions or weld-neck flanges on request at extra cost

BAE 39: Butt-weld ends for pipe according to

DIN 2448:	57.0 x 2.9 to 4.5 mm
	60.3 x 2.9 to 6.3 mm
	63.5 x 2.9 to 7.1 mm
	70.0 x 2.9 to 11.0 mm

ANSI B 36.10: 2" Schedule 80 and 160

Weld-neck flanges on request at extra cost

Sample valve

With 8 mm OD compression fitting

Materials

Body: BAE 36-210: forged steel
C 22.8 (No.1.0460 DIN)
BAE 211, BAE 39:
forged alloy steel
13 CrMo 4 4 (1.7335)

Internals: stainless steel

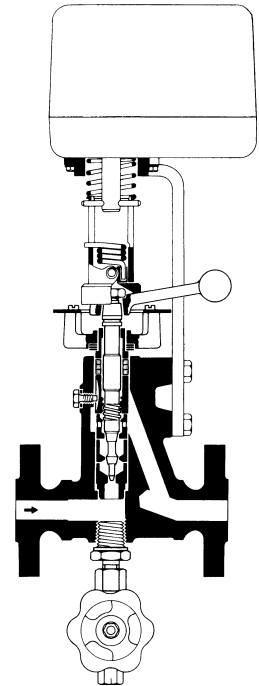

BAE 36, BAE 36-1, BAE 36-3

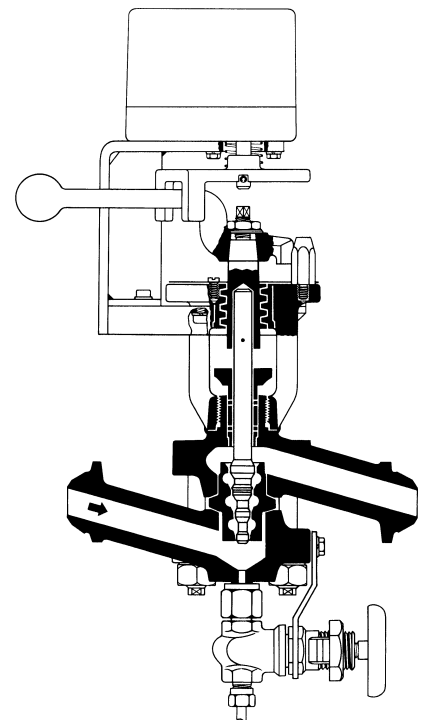

BAE 28-211

Dimensions

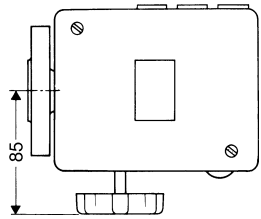
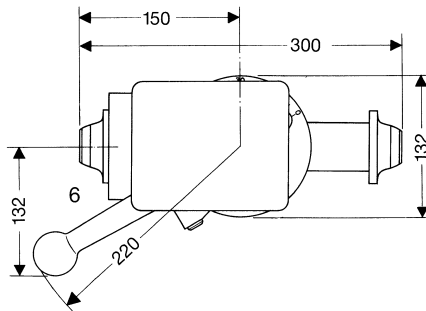
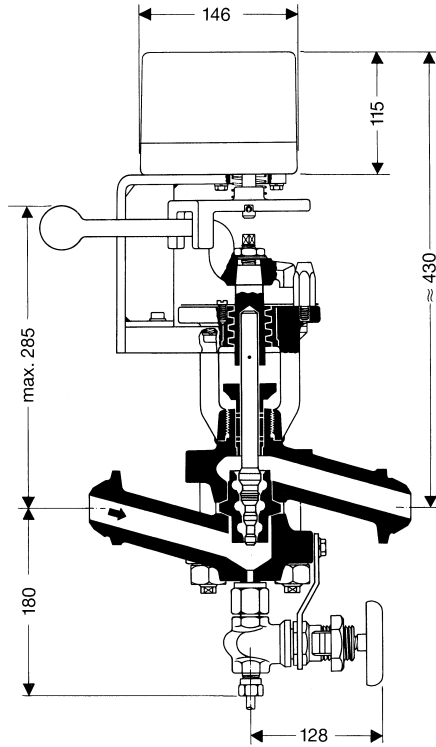
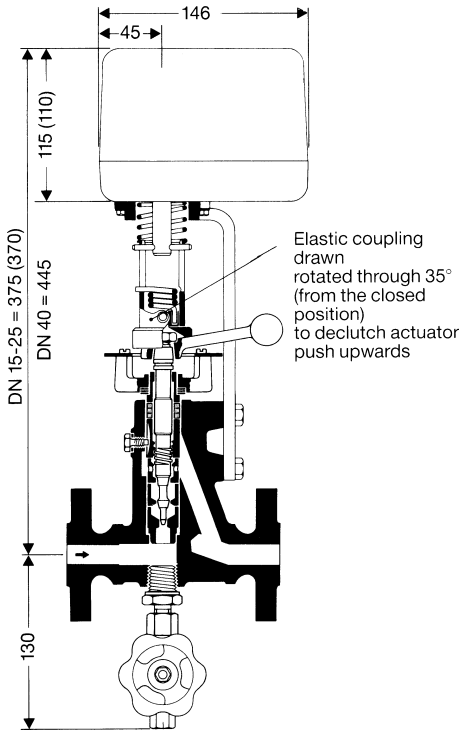

Dimensions of continuous blowdown valve type BAE 36, BAE 36-1, BAE 36-3 (approx. weight 9 kg)

Dimensions of continuous blowdown valve types BAE 28-211 (approx. weight 26 kg)

Dimensions in brackets refer to BAE 36-3

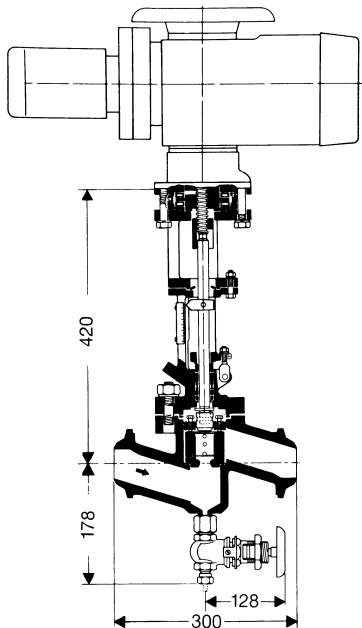

Dimensions of continuous blowdown valve type BAE 39 (approx. weight 55 kg)

Capacity Charts

The charts show the hot-water capacities with the various adjustments of the regulating lever corresponding to the number of scale divisions indicated in the chart (BAE 36-211) or, in the case of the BAE 39, the hot-water capacity corresponding to the valve lift indicated on the position indicator.

In purge position – regulating lever against stop – the capacity of the BAE 36 is, for example, three times the capacity at scale division 35.

If the boiler water downstream of the valve is lifted the differential pressure (working pressure) is reduced by approximately 1 bar for 7 m (or 2 psi for 3 feet) in lift.

Actuator

Actuator type

BAE 36:	EF 1
BAE 36-1:	EF1-1
BAE 36-3:	EF 0.5
BAE 28-211:	EF 2
BAE 39:	SA 0 7.5

Motor

BAE 36-211: short-circuit protected, single-pole reversible synchronous motor, 100 % duty cycle; gear with continuous lubrication
BAE 39: three-phase motor
other values on request

Mains supply

BAE 36, BAE 36-1,
BAE 36-3: 230 V +10/-15 %, 50 Hz, 5 VA
BAE 28-211: 230 V ±10 %, 50 Hz, 28 VA
BAE 39: 230/400 V, 50 Hz
other values on request

Switch for LOW (operating) position

1 single-pole change-over switch or
2 interlocking contactors

Positioning time

BAE 36-211: 120 s/90°
BAE 36-3: 100 s/90°
BAE 39: 45 s

Torque

BAE 36, BAE 36-1: 30 Nm
BAE 36-3: 15 Nm
BAE 28-211: 60 Nm
BAE 39: 30

Position-controlled limit switches

3 snap-action switches,
LOW (operating) position adjustable by cam
BAE 36-1: 2 snap-action switches
LOW (operating) position adjustable on controller LRR 1-9

Potentiometer

BAE 36-1: 1000 Ω precision potentiometer

Ambient temperature

BAE 36, BAE 36-1: 0...80 °C
BAE 36-3: -3...50 °C
BAE 28-211: -15...80 °C
BAE 39: 0...80 °C

Protection

BAE 36-211: IP 54
BAE 39: IP 65

Material

BAE 36, 36-1, 28-39: housing die-cast metal
BAE 36-3: housing die-cast metal
lid plastics

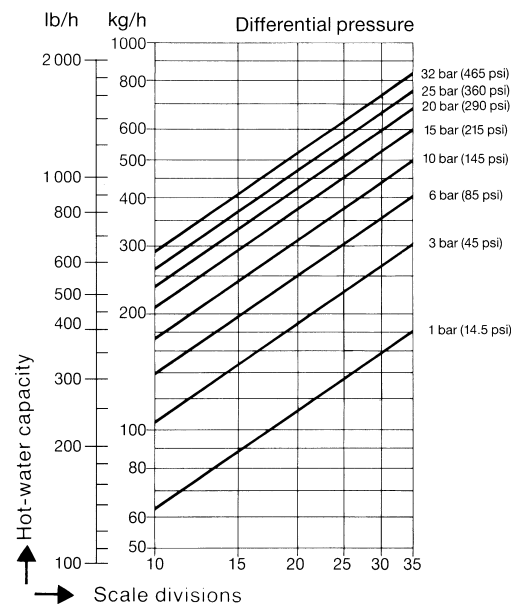

Chart 1: BAE 36k, BAE 36k-1/-3, DN 15, 20 mm (1/2", 3/4")

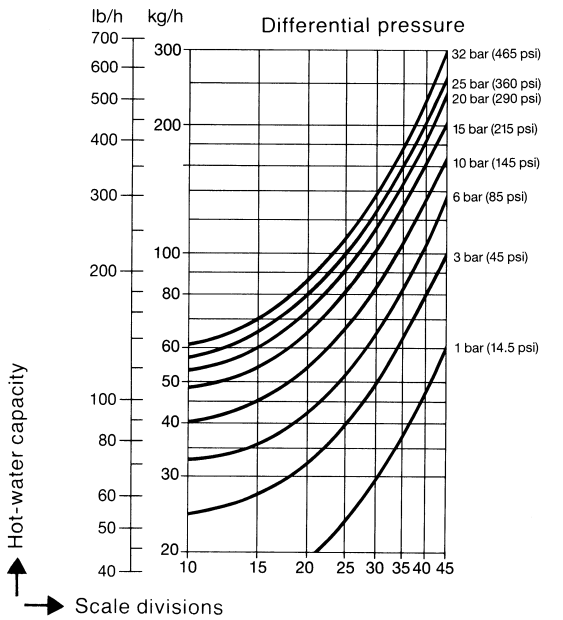

Chart 2: BAE 36kk, BAE 36kk-1/-3, DN 15, 20 mm (1/2", 3/4")
For very low capacities.

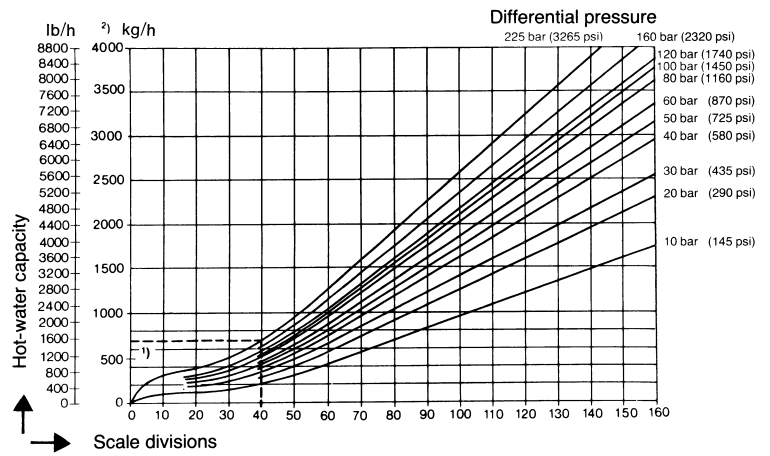

Chart 5: BAE 28, 29, 210, 211

- 1) For relatively small flowrates (see dotted lines in chart) use BA 29k, 210k or 211k (special stage nozzle). Scale divisions according to chart 6.
- 2) If the quantity of boiler water to be discharged is higher than the values covered by chart 5, GESTRA Reactomats BAE 39 with radial stage nozzle should be used (see chart 7).

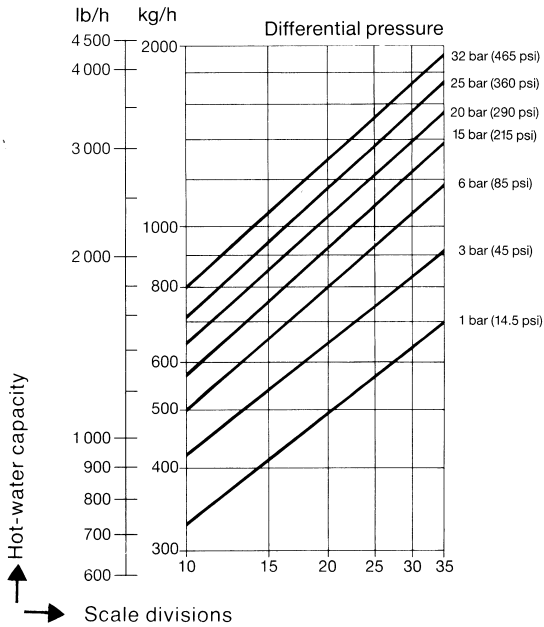

Chart 3: BAE 36, BAE 36-1/-3, DN 25 mm (1")

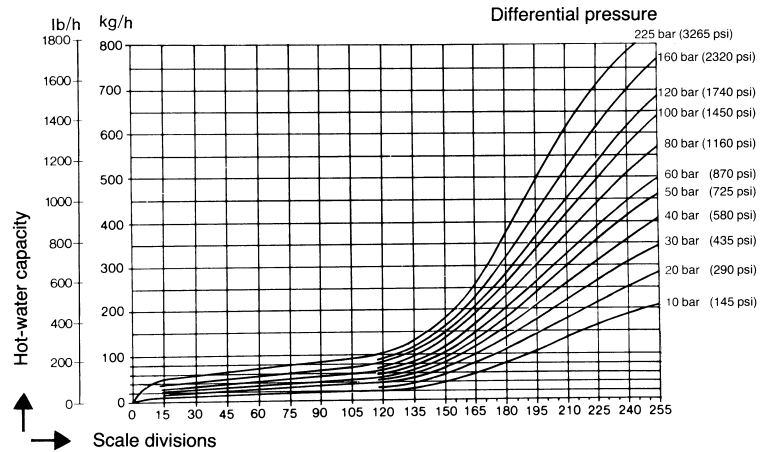

Chart 6: BAE 29k, 210k, 211k

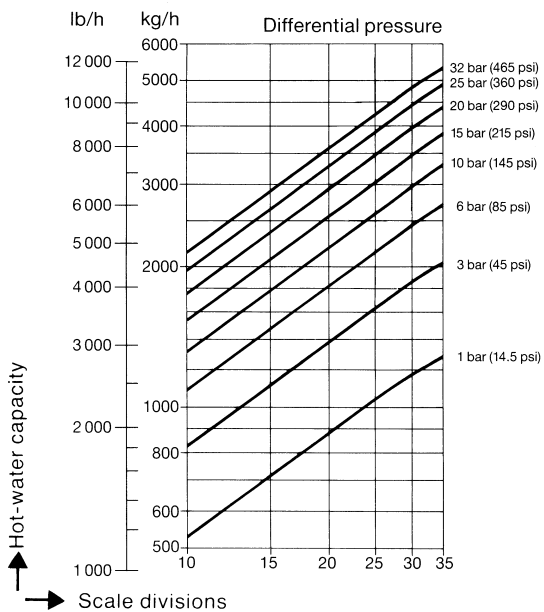

Chart 4: BAE 36, BAE 36-1, DN 40 mm (1 1/2")

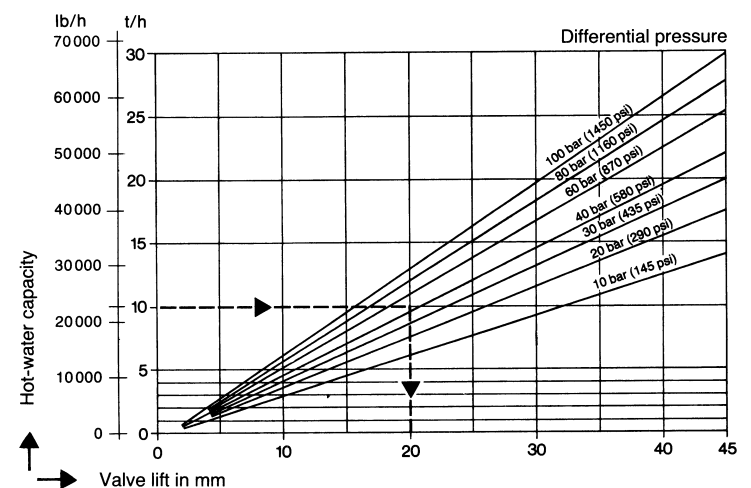

Chart 7: BAE 39

A₃

Blowdown Valves
PN 40–320
DN 15–50 mm
(1/2–2")

BAE



GESTRA GmbH

P. O. Box 10 54 60, D-28054 Bremen
Münchener Str. 77, D-28215 Bremen
Tel. +49 (0) 421 35 03-0, Fax -393
E-mail gestra.gmbh@gestra.de
Internet www.gestra.de



Flow Control Division

Important Notes

Connect continuous blowdown valve to blowdown line. Examples of installation are given in the data sheets ERL 16, LRG 16 and LRG 17, 19.

The blowdown rate of the continuous blowdown valve can be taken from the capacity charts.

When mounting the valves into steam boilers the relevant regulations must be considered.

Order and Enquiry Specifications

GESTRA continuous blowdown valve Reactomat for continuous blowdown control used with a GESTRA conductivity electrode and the continuous blowdown controller.

Continuous blowdown valve Reactomat type BAE ...
DN..., PN...,
Body material...
Internals stainless steel...
Electric actuator type...

The following test certificates can be issued on request, at extra cost:

In accordance with DIN 50049-2.1, -2.2 and -3.1 B.

All inspection requirements have to be stated with the order. After supply of the equipment certification cannot be established. For tests and inspection charges please consult us.

Associated Equipment

Conductivity electrode types ERL 16, LRG 16, LRG 17 or LRG 19.

Continuous blowdown controller type LRR 1-5b, LRR 1-6b with current output for remote conductivity indication on bar chart indicator type URA or ARZ.

Associated equipment for BAE 36-1 valve: Conductivity electrode type LRG 16-5, continuous blowdown controller type LRR 1-9 with automatic temperature compensation, digital display, current output for remote indication, signalling of MIN./MAX. limit values and automatic purging every 24 hours.

Wiring Diagrams

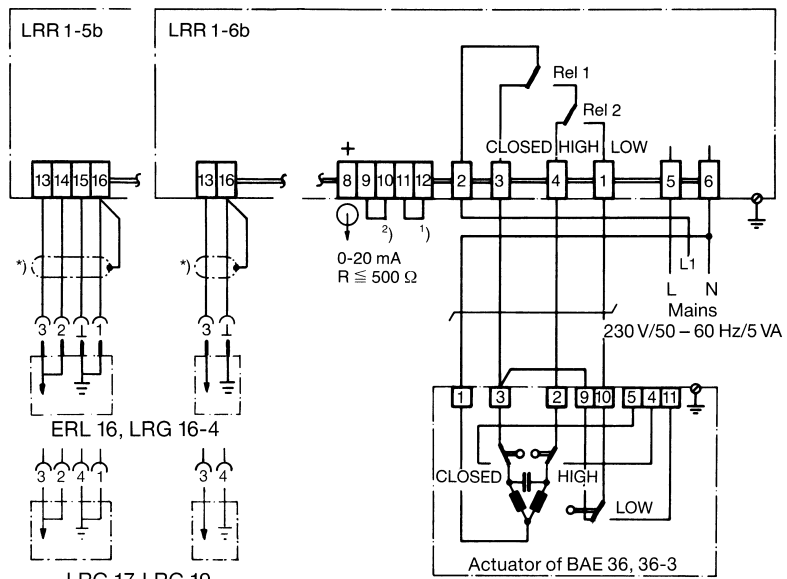

*) use screened cable and connect to terminals as follows:

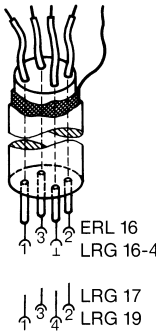
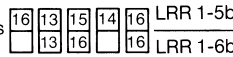

- 1) with wire link between 11-12: current output 4-20 mA
 - 2) with wire link between 9-10: operation as max.-min. limit switch (Rel 1 always energized when mains voltage switched on)
- L2: After burner shut-down, L1 must remain live until the actuator has closed the BAE valve

Wiring diagram for continuous blowdown controller type LRR 1-5b, 1-6b with conductivity electrode type ERL 16, LRG 16, LRG 17 or 19 and continuous blowdown valve type BAE 36, 28, 29, 210 or 211. For the BAE 39 a special wiring diagram applies.

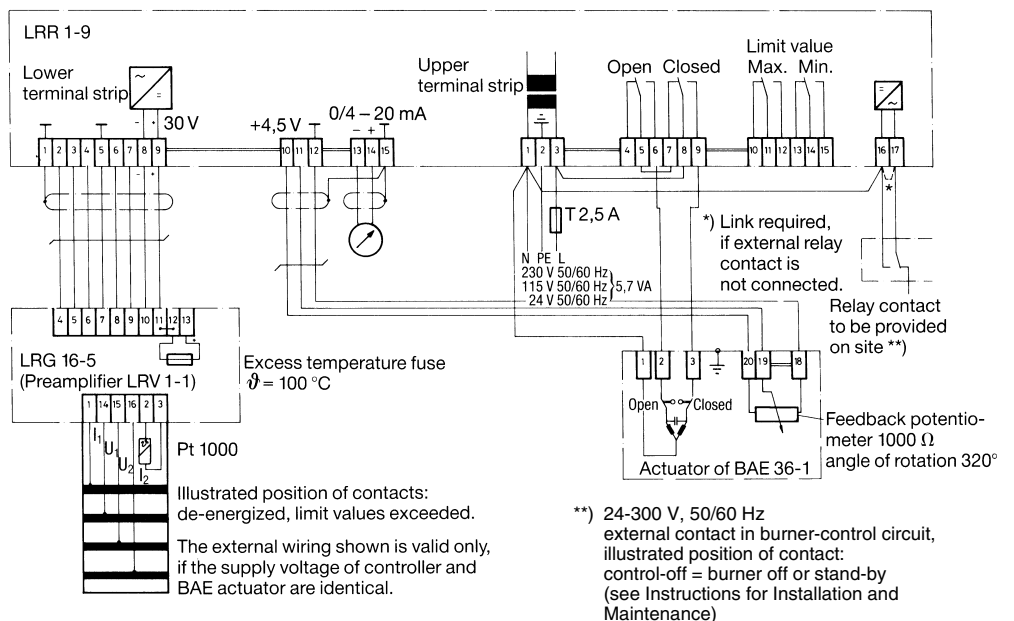

Wiring diagram for continuous blowdown controller type LRR 1-9 with conductivity electrode type LRG 16-5 and continuous blowdown valve type BAE 36-1.

Technical modifications reserved.