

DISCO® Non-Return Valves RK, PN 6 to PN 40

Short overall length according to DIN EN 558-1, table 11, series 49

(Δ DIN 3202, part 3, series K4)

RK 86 and RK 86 A – Our Robust All-Rounder

Application

Type	PN	
RK 86 RK 86 A	40/class 300 40/class 300	For liquids, gases, vapours. Application as gravity circulations check, vacuum breaker, breather, foot valve, pressure-maintaining valve, check valve. RK 86 A especially suited for low temperatures, aggressive fluids, boiler feedwater lines, and other industrial applications.

Body Material

Type	Nominal sizes DN	EN reference	ASTM equivalent 1)	
RK 86	Body	15 – 100 mm	Chromium steel, 1.4317	A 743-CA6-NM
	Valve disk		1.4571	AISI 316 Ti
	Body	125 – 200 mm	GP240GH (1.0619)	A 216 WCB
	Plug		1.4006	A182 F6 A
RK 86A	Body	15 – 100 mm	1.4408	A351 CF 8M
	Valve disk		1.4571	AISI 316 Ti
	Body	125 – 200 mm	1.4408	A351 CF 8M
	Plug		1.4404	A182 F316 L

1) ASTM material similar to EN material.

Observe different physical and chemical properties!

Dimensions

Nominal sizes	[mm]	15	20	25	32	40	50	65	80	100	125	150	200
	[Inch]	1/2	3/4	1	1 1/4	1 1/2	2	2 1/2	3	4	5	6	8
Overall dimensions [mm]	L	16	19	22	28	31,5	40	46	50	60	90	106	140
	∅ D min	44	53	64	73	83	96	110	128	151	–	–	–
	∅ D max	67	76	82	93	104	118	136	158	186	–	–	–
∅ D	PN 10/16	–	–	–	–	–	–	–	–	–	194	220	275
	PN 25	–	–	–	–	–	–	–	–	–	194	226	286
	PN 40	–	–	–	–	–	–	–	–	–	194	226	293
	Class 125/150	–	–	–	–	–	–	–	–	–	194	220	275
	Class 300	–	–	–	–	–	–	–	–	–	216	251	308
Weight [kg]		0.27	0.38	0.52	0.8	1.12	1.78	2.43	3.37	5.34	11	14	25

Pressure/Temperature Ratings with metal-to-metal seat

Typ	PN	DN	p / T / [bar] / [°C]		
RK 86	40/class 300	15 – 100	51 / -10	43.9 / 200	36.9 / 350
	40/class 300	125 – 200	51 / -10	43.9 / 200	34.5 / 400
RK 86 A	40/class 300	15 – 200	49.6 / -200	35.8 / 200	24 / 550

Designs

Type	Seat				Springs			Earthing connection
	metal-to-metal	EPDM (-40 up to 150°C) ²⁾	FPM (-25 up to 200°C) ²⁾	PTFE ³⁾	without spring	special spring	Nimonic spring ⁴⁾	
RK 86	X	0	0	0	0	0	0	X
RK 86A	X	0	0	0	0	0	0	X

2) Observe pressure/temp. ratings of the equipment

3) DN 15-100 –190 °C up to 250 °C; DN 125-200 –60 up to 200 °C

4) Required for temperatures above 300 °C

X : standard

0 : optional

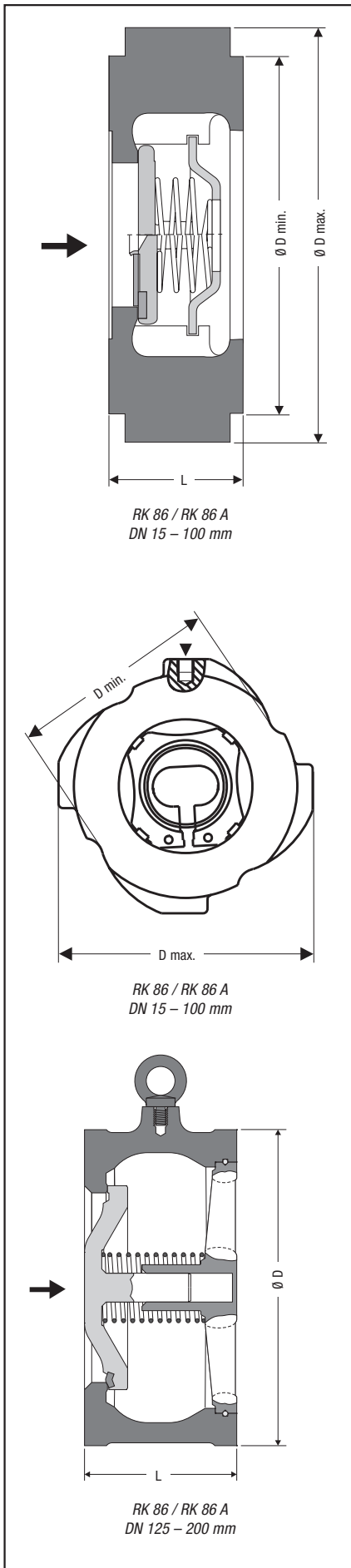

Pressure Drop Charts

The curves given in the chart are valid for water at 20 °C. To read the pressure drop for other fluids the equivalent water volume flowrate must be calculated and used in the graph.

The values indicated in the chart are applicable to spring-loaded valves with horizontal flow. With vertical flow insignificant deviations occur only within the range of partial opening.

$$\dot{V}_w = \dot{V} \cdot \sqrt{\frac{\rho}{1000}}$$

\dot{V}_w = Equivalent water volume flow in [l/s] or [m³/h]

ρ = Density of fluid (operating condition) in [kg/m³]

\dot{V} = Volume of fluid (operating condition) in [l/s] or [m³/h]

Opening Pressures

Differential pressures at zero volume flow.

RK 86, RK 86 A

DN	Opening pressures [mbar]			
	without spring ↑	Direction of flow		
		↑	→	↓
15	2.5	10	7.5	5
20	2.5	10	7.5	5
25	2.5	10	7.5	5
32	3.5	12	8.5	5
40	4.0	13	9	5
50	4.5	14	9.5	5
65	5.0	15	10	5
80	5.5	16	10.5	5
100	6.5	18	11.5	5
125	12.5	35	22.5	10
150	14.0	38	24.0	10
200	13.5	37	23.5	10

RK 86, 86A

When selecting valve please consider:

Partial opening/
instable range

Full opening/
stable range

