

Features of the UNA series

- Unaffected by back pressure and condensate temperature
- No loss of live steam due to continuous water seal at the seat
- No banking-up of condensate even with extreme load and pressure fluctuations
- Particularly well suited for heat exchangers controlled from the steam side
- Unaffected by dirt
- Automatic thermostatic air-venting (Duplex design)
- Ideal for discharging cold condensates, distillates and condensates derived from chemical products (Simplex design)
- Repairable in-line
- Thanks to the rolling ball valve only reduced operating forces and small control units are required (compact, lightweight design for large flowrates)
- Internals made from corrosion-resistant stainless steels

Application

Condensate discharge without banking-up, even at varying operating conditions and back pressure. Automatic air-venting (Duplex design). Also for the discharge of cold condensates and distillates, and for draining gas and compressed air systems (Simplex design).

Pressure/Temperature Ratings and Designs **)

Type	PN	ΔPMX [bar]	Werkstoffe		Druck-/Temperaturgrenzen	
			EN	ASTM ¹⁾	PMA / TMA	PMA / TMA
UNA 14	25	13	EN-JS 1049	–	25 bar / 20 °C	15 bar / 350 °C
UNA 23	16	13	EN-JL 1040	A126 Cl. B	16 bar / 120 °C	9.6 bar / 300 °C
UNA 16	40	22	1.0460; 1.0619	A105; A216 WCB	40 bar / 20 °C	23.1 bar / 400 °C
UNA 25	40	32	EN-JS 1049	–	32 bar / 250 °C	25 bar / 350 °C
UNA 26	40	32	1.0460; 1.0619	A105; A216 WCB	32 bar / 250 °C ³⁾	21 bar / 400 °C
UNA 27 h	63	45	1.5419	A217 WC1	56 bar / 250 °C	40.6 bar / 450 °C
UNA 38	100	80	1.5415 ⁴⁾	A182-F1	100 bar / 150 °C	44 bar / 500 °C
UNA 39	160	140	1.7335	A182 F12	160 bar / 300 °C	35 bar / 550 °C
UNA-Special Typ 62	16	16	EN-JL 1040	A126 Cl. B	16 bar / 120 °C	9.6 bar / 300 °C
UNA-Special	25	22	1.0619	A216 WCB	22.6 bar / 120 °C	14.4 bar / 400 °C
UNA	25	22	1.0619	A216 WCB	22.6 bar / 120 °C	14.4 bar / 400 °C
UNA-Special	63	45	1.5419	A217 WC1	56 bar / 250 °C	40.6 bar / 450 °C
UNA 16 A	40	22	1.4404 ²⁾ 1.4308 ²⁾	A182 F 316L ²⁾ A351 CF8 ²⁾	40 bar / –196 °C / 20 °C	25.8 bar / 300 °C
UNA 26 h	40	32	1.4408	A351 CF8 M	40 bar / 20 °C	25.8 bar / 300 °C

1) ASTM nearest equivalent grade is stated for guidance only. Physical and chemical properties comply with EN grade.

2) Body/cover material

3) UNA 26 DN 40, DN 50: 26 bar/250 °C

4) Body 1.5415, cover 1.7357

**)) For more information see data sheet.

h: for horizontal lines

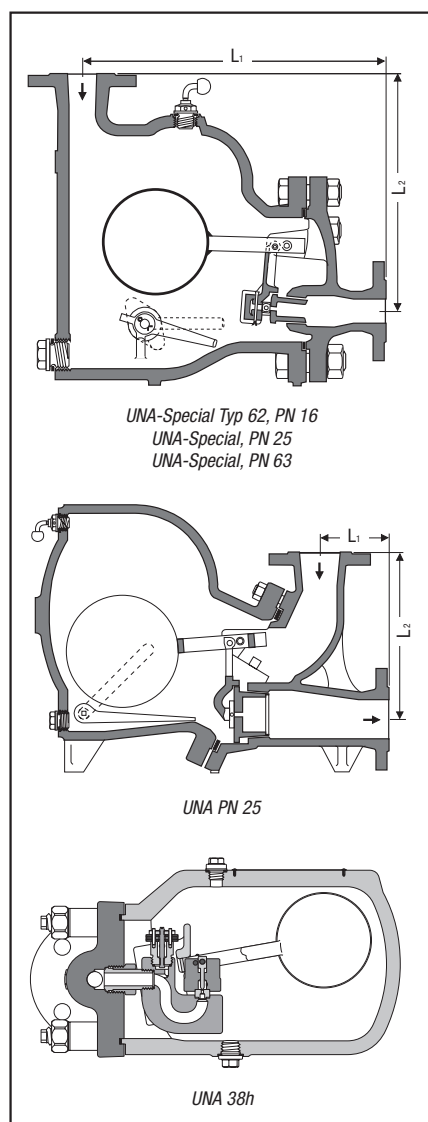

Available End Connections and Overall Length

Type	Connection	Overall length (L) in mm				
		DN 15 1/2"	DN 20 3/4"	DN 25 1"	DN 40 1 1/2"	DN 50 2"
UNA 14h, 14v	Flanged EN PN 25	150	150	160	–	–
	Screw sockets	95	95	95	–	–
UNA 16h, 16v, UNA 16Ah, 16Av	Flanged EN PN 40	150	150	160	–	–
	Flanged ASME 150 RF	150	150	160	–	–
	Screw sockets	95	95	95	–	–
	Socket-weld (SW)	95	95	95	–	–
UNA 23h, 23v	Flanged EN PN 16	150	150	160	230	230
	Flanged EN PN 40	150	150	160	230	230
UNA 25h, 25v	Flanged EN PN 40	150	150	160	230	230
UNA 26h, 26v	Flanged EN PN 40	150	150	160	230	230
UNA 26h	Flanged EN PN 40	210	210	230	320	320
UNA 26h	Flanged ASME 150 + 300 RF	210	210	230	320	320
	Screw sockets	200	200	200	255	255
	Socket-weld (SW)	200	200	200	230	230
	Butt-weld (BW)	200	200	200	230	230
UNA 27h ¹⁾ and UNA 38	Flanged EN PN 63/PN 100	300	–	300	420	416
	Flanged ASME 600 RF	300	–	300	421	427
UNA 38	Socket-weld / SW via transition pieces	300	–	300	420 ²⁾	420 ²⁾
	Butt-weld / BW via transition pieces	300	–	300	420 ²⁾	420 ²⁾
UNA 39	Flanged EN PN 160	L ₁ /L ₂	–	L ₁ /L ₂	–	L ₁ /L ₂
	Flanged ASME 900 RF	215/285	–	230/300	–	245/315
	Butt-weld (BW)	250/320	–	260/330	–	280/350
UNA 39	Flanged EN PN 160	170/240	–	170/240	–	170/240
	Flanged ASME 900 RF	215/285	–	230/300	–	245/315
	Butt-weld (BW)	250/320	–	260/330	–	280/350

¹⁾ not available as DN 15 ²⁾ UNA 38 socket-weld (SW) ends and butt-weld (BW) ends DN 40 + DN 50: 300 mm, SW and BW via transition pieces: 420 mm

Type	Connection	Length L ₁ /L ₂ in mm			
		DN 50 2"	DN 65 2 1/2"	DN 80 3"	DN 100 4"
UNA-Special Typ 62, PN 16	Flanged EN PN 16	L ₁	–	470	490
		L ₂	–	395	420
UNA-Special PN 25	Flanged EN PN 25	L ₁	445	470	–
		L ₂	345	395	–
UNA PN 25	Flanged EN PN 25	L ₁	–	–	140
		L ₂	–	–	335
UNA-Special PN 63	Flanged EN PN 63	L ₁	–	565	690
		L ₂	–	400	435

Simplex: Float control (without thermostatic bellows)
Duplex: Flow control + automatic air-venting
Simplex-R: Float control + inner vent pipe

Available Designs

Type	End connection options			Orifice (O) for max. differential pressure	Control unit		
	horizontal	vertical	angle pattern		Simplex	Duplex	Simplex-R
UNA 14	x ¹⁾	x ¹⁾		0 4, 13	x	x	x
UNA 16, 16A	x ¹⁾	x ¹⁾		0 4, 13, 22	x	x	x
UNA 23	x	x		0 2, 4, 8, 13, 4 max.*), 8 max.*), 13 max.*)	x	x	x
UNA 25/26	x	x		0 2, 4, 8, 13, 22, 32, 4 max.*), 8 max.*), 13 max.*)	x	x	x
UNA 27h	x			0 16, 28, 45	x	x	
UNA 38	x ¹⁾	x ¹⁾		0 50, (64), 80, 80 max.	x	x	
UNA 39			x	0 80, 110, 140, 140 max.	x		
UNA-Special Typ 62, PN 16			x	0 2 ²⁾ 3), 3.5 ⁴⁾ , 5, 10, 16	x ⁶⁾	x ²⁾⁷⁾	
UNA-Special PN 25			x	0 2 ³⁾ , 3.5 ⁴⁾ , 5, 10, 16, 22	x ⁶⁾	x ⁷⁾	
UNA PN 25			x	0 2, 3.5, 5, 8, 12, 16, 22	x ⁶⁾		
UNA-Special PN 63			x	0 16, 22, 32, 40, 45	x ⁶⁾		

¹⁾ A conversion of "h" to "v" or vice versa is possible

²⁾ This design is not available for DN 100 mm

³⁾ This design is not available for DN 80 mm

⁴⁾ This design is not available for DN 65 mm

⁵⁾ This design is not available for DN 50 mm

⁶⁾ Simplex: Flow control + hand vent valve + float lifting lever

⁷⁾ Duplex: Flow control + automatic air-venting

^{*)} DN 40, DN 50

Optional Items for Ball-Float Traps

Item	Type
Sightglass cover	UNA 23
Float lifting lever with gasket	UNA 23, 25, 26 (UNA 27 h and 38 on request)
Vent valve with gasket (for Duplex design)	UNA 23, 25, 26, 27 h, 38

Capacity Charts

The charts show the maximum hot condensate capacities for the range of float-controlled orifices (O) and sizes available.

UNA 14, UNA 16

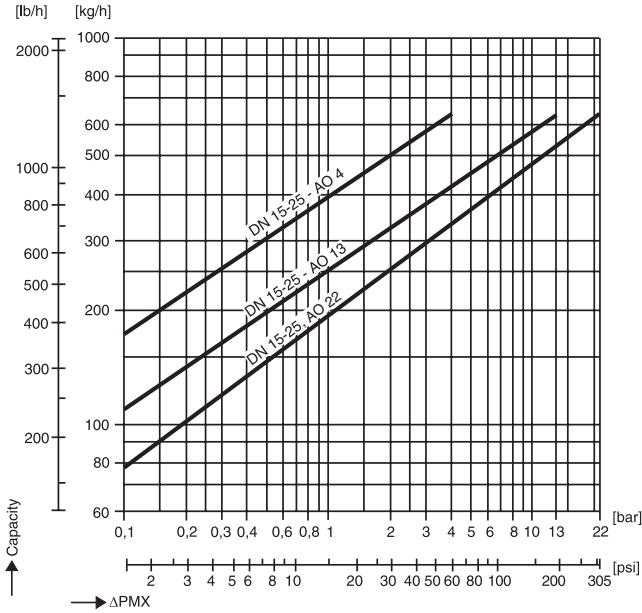

UNA 23, UNA 25, UNA 26

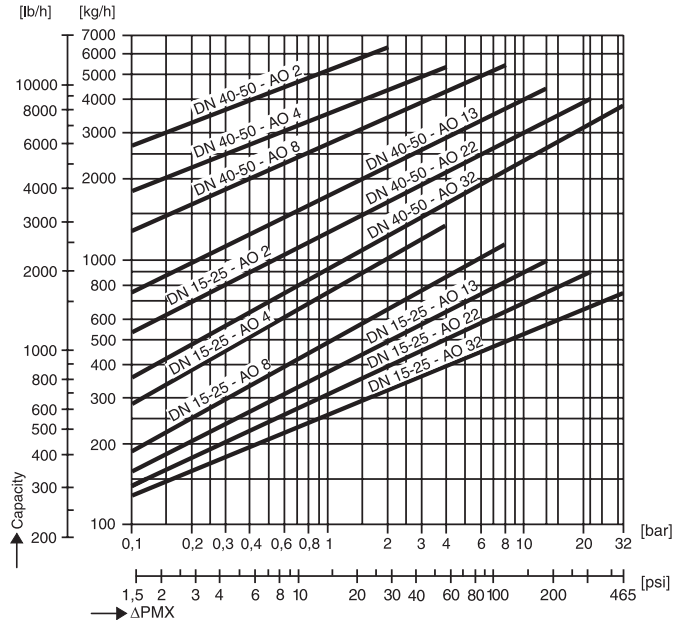

UNA 27 h

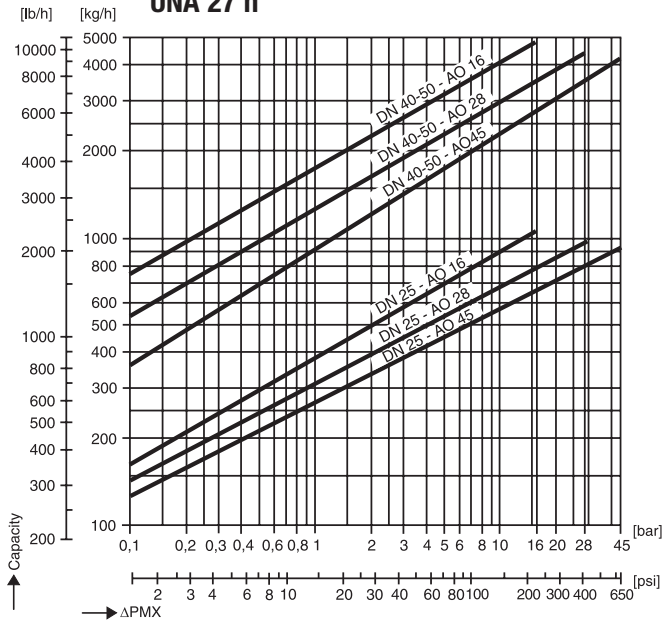

UNA 23, 25, 26 max.

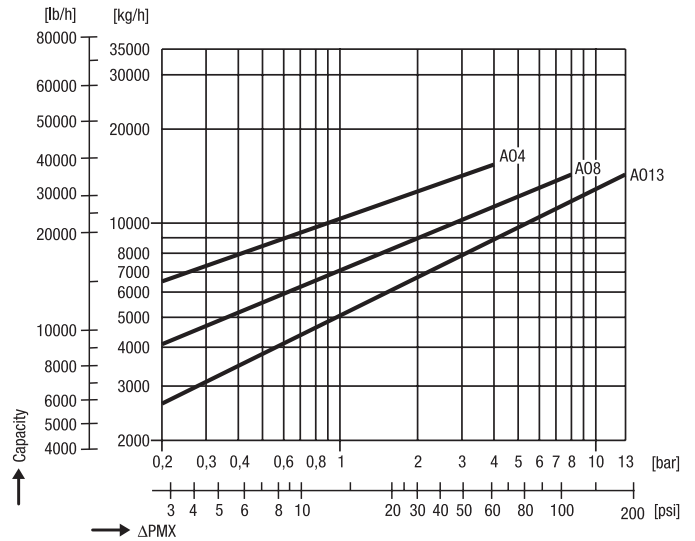

UNA 38, AO 50, 64, 80

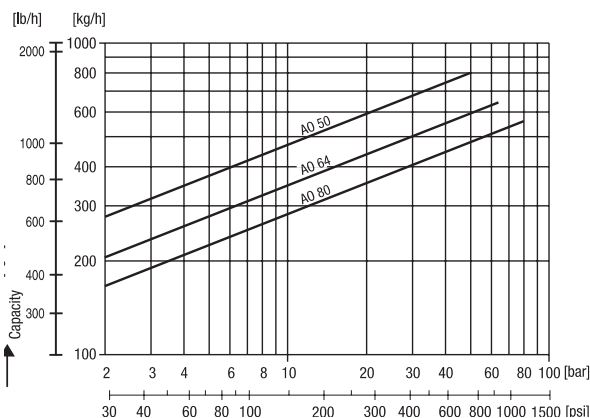

UNA 38, AO 80 max

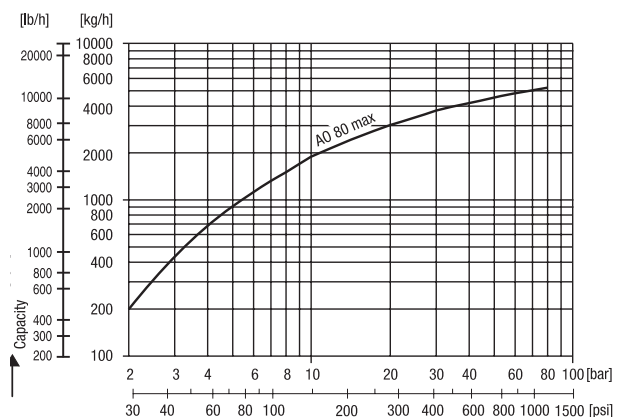

Capacity Charts

The charts show the maximum hot condensate capacities for the range of orifices (O) and sizes available.

UNA 39, DN 15, 25 and 50

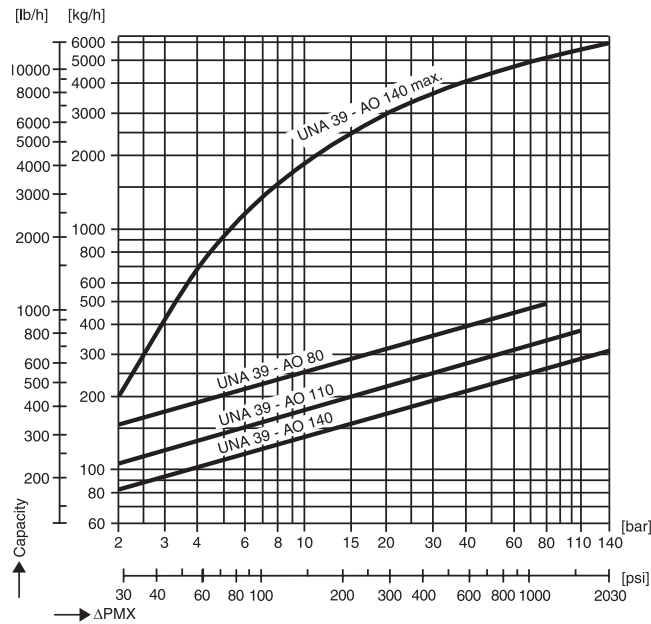

UNA-Special Typ 62, PN 16

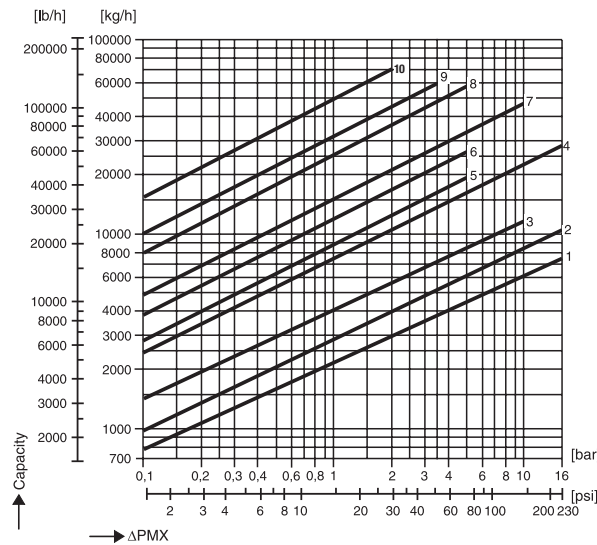

Available orifices (O)		
1	DN 65	O 16
2	DN 65	O 10
	DN 80	O 16
3	DN 80	O 10
4	DN 100	O 16
5	DN 65	O 5
6	DN 80	O 5
7	DN 65	O 2
	DN 80	O 3.5
	DN 100	O 10
8	DN 100	O 5
9	DN 100	O 3.5
10	DN 100	O 2

UNA PN 25, DN 80 and 100

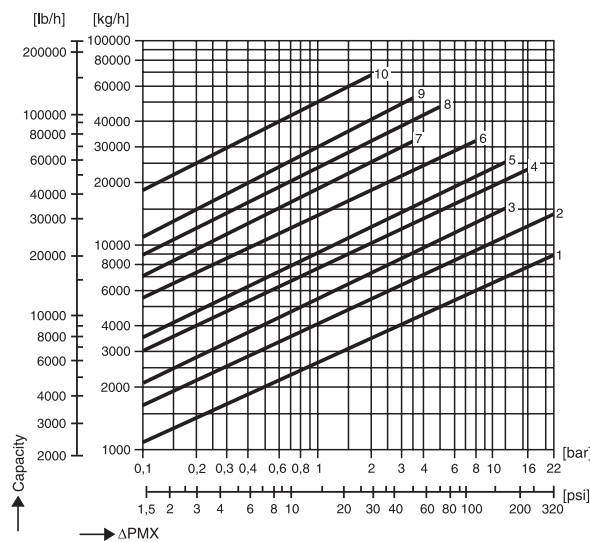

Available orifices (O)		
1	DN 80	O 22
2	DN 80	O 16
	DN 100	O 22
3	DN 80	O 12
4	DN 100	O 16
5	DN 80	O 8
	DN 100	O 12
6	DN 80	O 5
	DN 100	O 8
7	DN 80	O 3.5
8	DN 100	O 5
9	DN 80	O 2
	DN 100	O 3.5
10	DN 100	O 2

Capacity Charts

The charts show the maximum hot condensate capacities for the range of orifices (O) and sizes available.

UNA-Special PN 25, DN 50 and 65

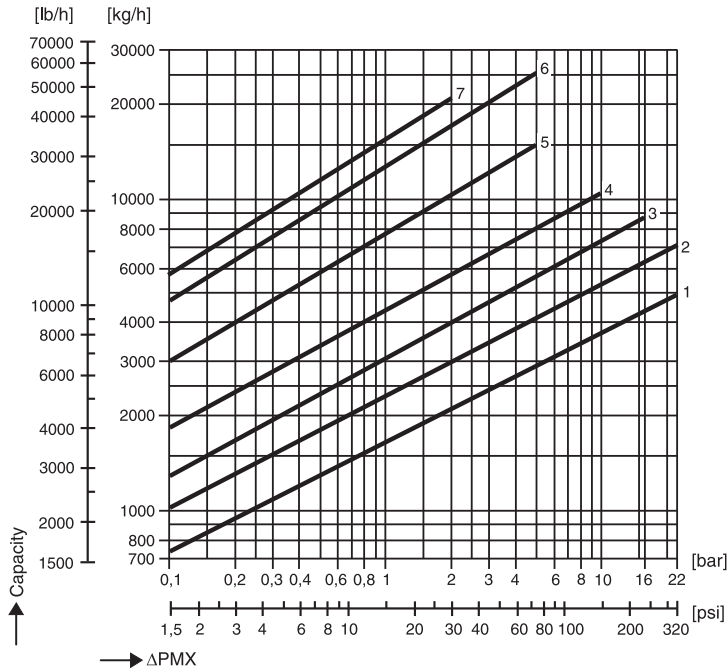

Available orifices (O)		
1	DN 50	O 22
2	DN 50	O 16
	DN 65	O 22
3	DN 50	O 10
	DN 65	O 16
4	DN 65	O 10
5	DN 50	O 5
	DN 65	O 5
6	DN 50	O 3.5
	DN 65	O 5
7	DN 65	O 2

UNA-Special PN 63 (PN 40)

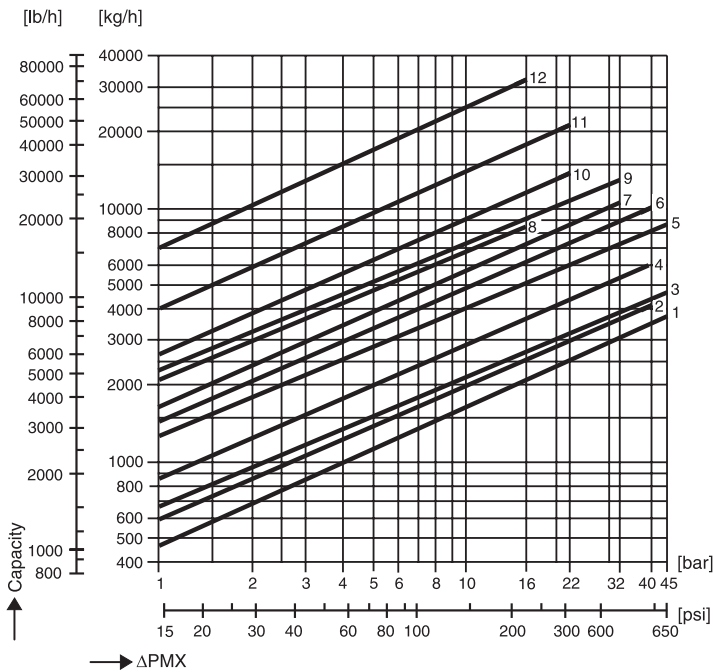

Available orifices (O)		
1	DN 65	O 45
2	DN 65	O 40
3	DN 80	O 45
4	DN 65	O 32
	DN 80	O 40
5	DN 100	O 45
6	DN 65	O 22
	DN 100	O 40
7	DN 80	O 32
8	DN 65	O 16
9	DN 100	O 32
10	DN 80	O 22
11	DN 80	O 16
	DN 100	O 22
12	DN 100	O 16