

Condensate collection / Steam distribution

**CODI® S 671/672 - 02 to 18**

with gland packing  
PN40 / PN63

**Vertical installation:**

- with flanges (Fig. 671....1)
- with socket weld ends (Fig. 671....3)
- with butt weld ends (Fig. 671....4)

**Horizontal installation:**

- with flanges (Fig. 672....1)
- with socket weld ends (Fig. 672....3)
- with butt weld ends (Fig. 672....4)

Forged steel  
Stainless steel

Page 2

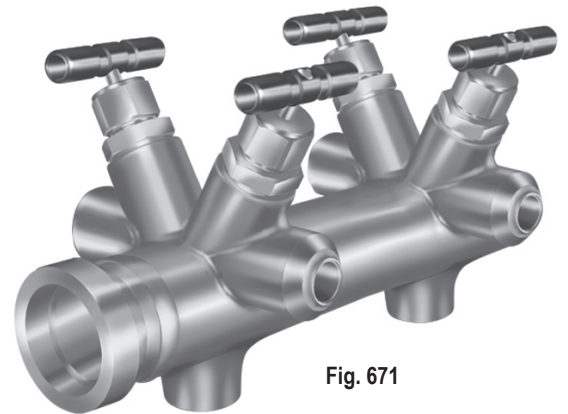
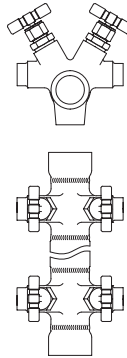

Fig. 671

**CODI® B 675/676 - 02 to 18**

with bellows seal (maintenance-free)  
PN40 / PN63

**Vertical installation:**

- with flanges (Fig. 675....1)
- with socket weld ends (Fig. 675....3)
- with butt weld ends (Fig. 675....4)

**Horizontal installation:**

- with flanges (Fig. 676....1)
- with socket weld ends (Fig. 676....3)
- with butt weld ends (Fig. 676....4)

Forged steel  
Stainless steel

Page 4

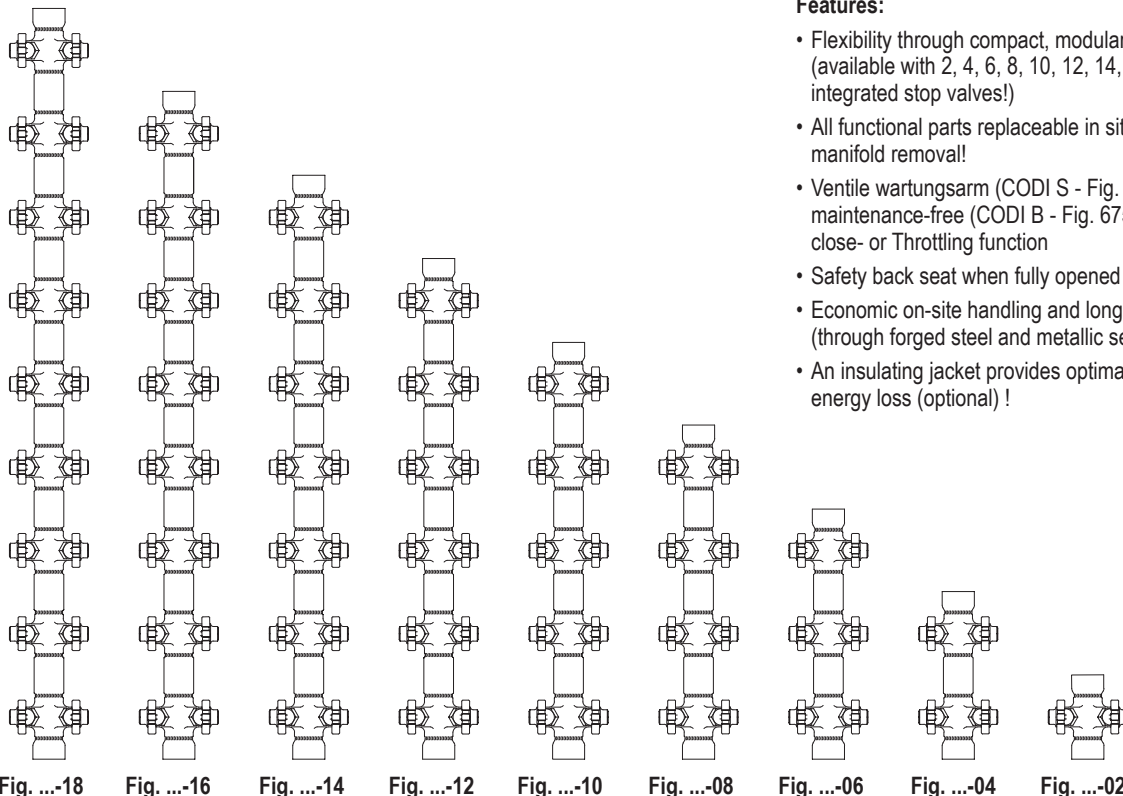
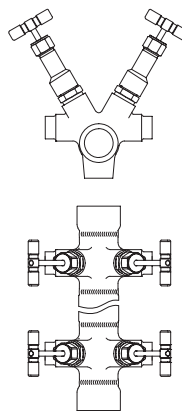

**Features:**

- Flexibility through compact, modular design (available with 2, 4, 6, 8, 10, 12, 14, 16 or 18 integrated stop valves!)
- All functional parts replaceable in situ - no need for manifold removal!
- Ventile wartungsarm (CODI S - Fig. 671 / 672) or maintenance-free (CODI B - Fig. 675 / 676) with Open-close- or Throttling function
- Safety back seat when fully opened valve!
- Economic on-site handling and long life (through forged steel and metallic sealing...)
- An insulating jacket provides optimal protection against energy loss (optional) !

**Manifolds for condensate collection and steam distribution with stuffing box (Forged steel)**

**Fig. 671 / 672 Module complete**

Figure	Nominal pressure	Material	Nominal diameter / NPS	Operating pressure PS	Inlet temperature TS
45.671... 45.672...	PN40	1.0460	Primary connections DN 25 / 40 / 50 1" / 1 1/2" / 2"	32 barg	250 °C
...-02 (each 1 second. connection) ...-04 (each 2 second. connection) ...-06 (each 3 second. connection)				21 barg	400 °C
55.671... 55.672...	PN40	1.4541 or 1.4404	Secondary connection DN 15 / 20 / 25 1/2" / 3/4" / 1"	32 barg	350 °C
...-08 (each 4 second. connection) ...-10 (each 5 second. connection) ...-12 (each 6 second. connection)				22 barg	400 °C
46.671... 46.672...	PN63	1.0460		45 barg	250 °C
...-14 (each 7 second. connection) ...-16 (each 8 second. connection) ...-18 (each 9 second. connection)				32 barg	400 °C

For ANSI versions refer to data sheet CODI®-ANSI

Plug design	
standard:	• Isolation plug (Open-close function)
optional:	• Throttling plug (Throttling function)
Safety back seat when fully opened valve	
Types of connection (Standard)	
Other types of connection on request.	
<b>Primary connections:</b> (top and bottom)	<ul style="list-style-type: none"> <li>Flanges ....1 _____ acc. to DIN 2635 or DIN EN 1092-1 (PN40), DIN 2636 or DIN EN 1092-1 (PN63)</li> <li>Screwed sockets ....2 _____ Rp thread acc. to DIN EN 10226-1 or NPT thread acc. to ANSI B1.20.1</li> </ul>
<b>Secondary connection:</b> (left and right)	<ul style="list-style-type: none"> <li>Socket weld ends ....3 _____ acc. to DIN EN 12760</li> <li>Butt weld ends ....4 _____ Weld preparation acc. to EN ISO 9692 identification No. 1.3 and 1.5 (Note restriction on operating pressure / inlet temperature depending to design!)</li> </ul>
Features	
<ul style="list-style-type: none"> <li>Flexibility through compact, modular design (available with 2, 4, 6, 8, 10, 12, 14, 16 or 18 integrated stop valves!)</li> <li>All functional parts replaceable in situ - no need for manifold removal!</li> <li>Safety back seat when fully opened valve!</li> <li>Economic on-site handling and long life (through forged steel and metallic sealing...)</li> </ul>	
Mounting position	
• Preferably vertical	Threaded connection M12 are provided at the back for the attachment to a supporting structure.
Options	
(Design refer to page 8)	
<ul style="list-style-type: none"> <li>Insulating jacket</li> <li>Immersion tube</li> </ul>	<ul style="list-style-type: none"> <li>Fastening parts (set)</li> <li>Mounting wrench</li> </ul>

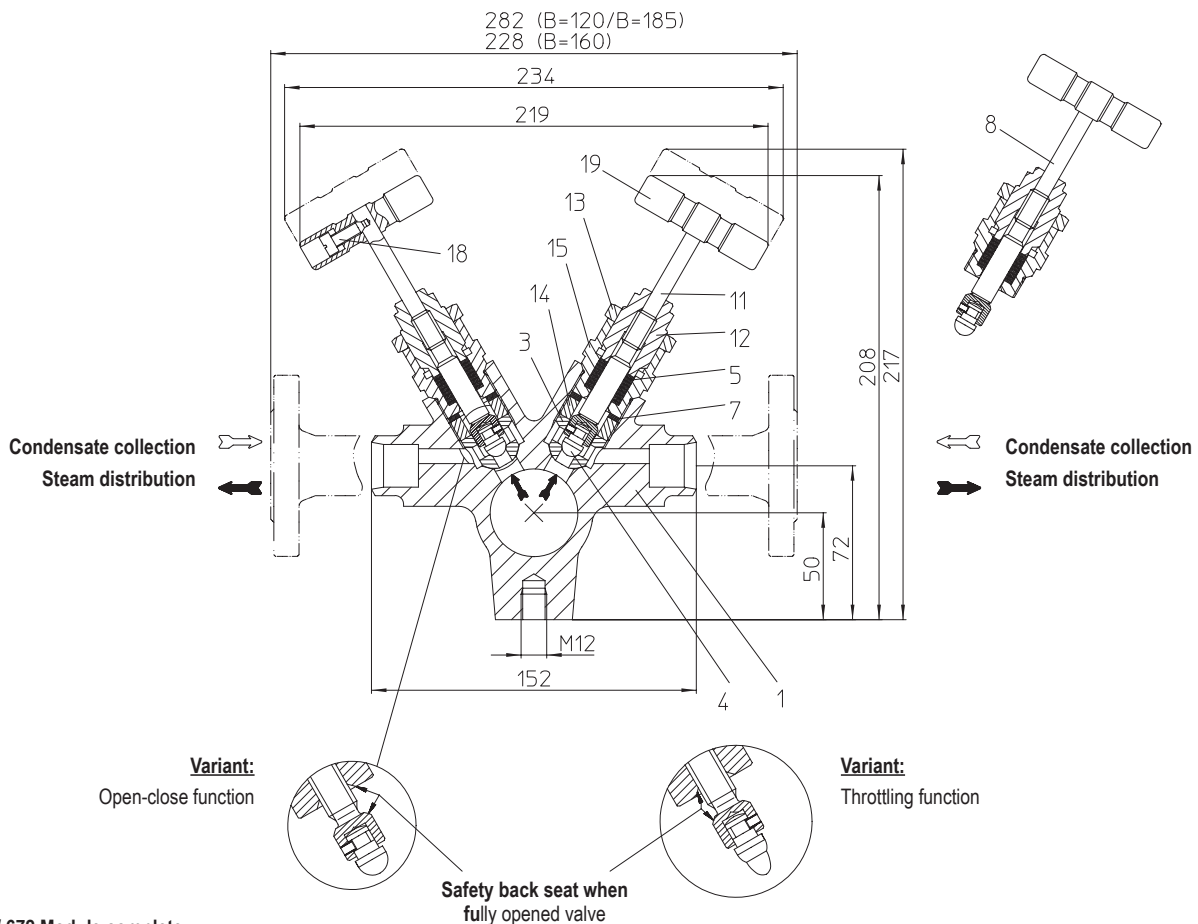
Parts				
Pos.	Sp.p.	Description	Fig. 45.671 / 45.672 Fig. 46.671 / 46.672	Fig. 55.671 / 55.672
1		Body	P250GH, 1.0460	X6CrNiTi18-10, 1.4541 or X2CrNiMo17-12-2, 1.4404
2		Connection between the modules	P325GH-TC1, 1.0305	X2CrNiMo17-12-2, 1.4404
3	x	Seat	X8CrNiS18-9, 1.4305	
4		Valve ball	X39CrMoS17+QT, 1.4122+QT	
5	x	Packing ring	Pure graphite	
7		Sealing ring	Graphite	
8	x	Assembly stop valve, cpl.	X6CrNiMoTi17-12-2, 1.4571	
11		Stem	X2CrNiMo17-12-2, 1.4404	
12		Threaded bush	X39CrMoS17+QT, 1.4122+QT	
13		Safety nut	X8CrNiS18-9, 1.4305	
14		Banjo bolt	X8CrNiS18-9, 1.4305	
15		Fitting	X8CrNiS18-9, 1.4305	
18	x	Cheese head screw	A2-70	
19	x	Hand grip	X14CrMoS17+QT, 1.4104+QT	
		Other interior parts	Stainless steel	
	L Spare parts			

Information / restriction of technical rules need to be observed!

Resistance and fitness must be verified (contact manufacturer for information, refer to Product overview and Resistance list).

Operating and installation instructions can be downloaded at [www.ari-armaturen.com](http://www.ari-armaturen.com).

DN		15	20	25	40	50
Length B1	B = 120 mm (mm)	81	81	81	81	81
	B = 160 mm (mm)	118	118	118	138	138

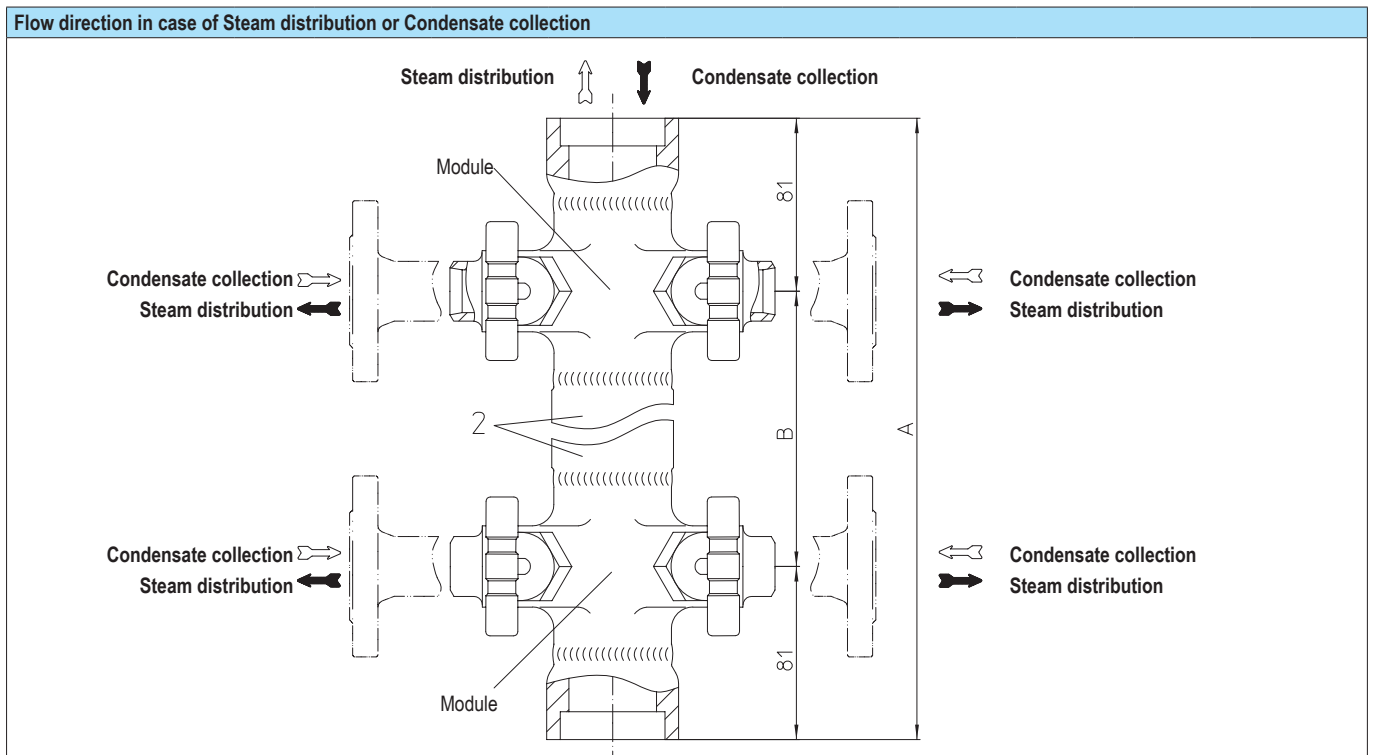

Dimensions and weights		Face-to-face acc. to data sheet resp. customer request								
Fig. 671 / 672		... -02	... -04	... -06	... -08	... -10	... -12	... -14	... -16	... -18

PN40		B = 120 mm								Standard-flange dimensions refer to page 7	
Dimension A	(mm)	162	282	402	522	642	762	882	1002	1122	
Weight (approx.)	(kg)	3,5	7,2	10,7	14,7	17,7	21,2	24,7	28,2	31,7	

PN40		B = 160 mm								Standard-flange dimensions refer to page 7	
Dimension A	(mm)	162	322	482	642	802	962	1122	1282	1442	
Weight (approx.)	(kg)	3,5	7,5	11	14,5	18	21,5	25	28,5	32	

PN63		B = 185 mm								Standard-flange dimensions refer to page 7	
Dimension A	(mm)	162	347	532	717	902	1087	1272	1457	1642	
Weight (approx.)	(kg)	4	8,5	12,5	16,5	20,5	24,5	28,5	32,5	36,5	

**Condensate collection and Steam distribution with bellows seal maintenance-free (Forged steel)**

**Fig. 675 / 676 Module complete**

Figure	Nominal pressure	Material	Nominal diameter / NPS	Operating pressure PS	Inlet temperature TS
45.675... 45.676...	PN40	1.0460	Primary connections DN 25 / 40 / 50 1" / 1 1/2" / 2"	32 barg	250 °C
...-02 (each 1 second. connection) ...-04 (each 2 second. connection) ...-06 (each 3 second. connection)				21 barg	400 °C
55.675... 55.676...				32 barg	350 °C
...-08 (each 4 second. connection) ...-10 (each 5 second. connection) ...-12 (each 6 second. connection)	PN40	1.4541 or 1.4404	Secondary connection DN 15 / 20 / 25 1/2" / 3/4" / 1"	22 barg	400 °C
46.675... 46.676...				45 barg	250 °C
...-14 (each 7 second. connection) ...-16 (each 8 second. connection) ...-18 (each 9 second. connection)	PN63	1.0460		32 barg	400 °C

For ANSI versions refer to data sheet CODI®-ANSI

Plug design	
standard:	• Isolation plug (Open-close function)
optional:	• Throttling plug (Throttling function)
Safety back seat when fully opened valve	
Types of connection (Standard)	
Other types of connection on request.	
<b>Primary connections:</b> (top and bottom)	• Flanges ....1 _____ acc. to DIN 2635 or DIN EN 1092-1 (PN40), DIN 2636 or DIN EN 1092-1 (PN63)
	• Screwed sockets ....2 _____ Rp thread acc. to DIN EN 10226-1 or NPT thread acc. to ANSI B1.20.1
<b>Secondary connection:</b> (left and right)	• Socket weld ends ....3 _____ acc. to DIN EN 12760
	• Butt weld ends ....4 _____ Weld preparation acc. to EN ISO 9692 identification No. 1.3 and 1.5 (Note restriction on operating pressure / inlet temperature depending to design!)
Features	
<ul style="list-style-type: none"> <li>Flexibility through compact, modular design (available with 2, 4, 6, 8, 10, 12, 14, 16 or 18 integrated stop valves!)</li> <li>All functional parts replaceable in situ - no need for manifold removal!</li> <li>Safety back seat when fully opened valve!</li> <li>Economic on-site handling and long life (through forged steel and metallic sealing...)</li> </ul>	
Mounting position	
• Preferably vertical	Threaded connection M12 are provided at the back for the attachment to a supporting structure.
Options	
(Design refer to page 8)	
• Insulating jacket	• Fastening parts (set)
• Immersion tube	• Mounting wrench

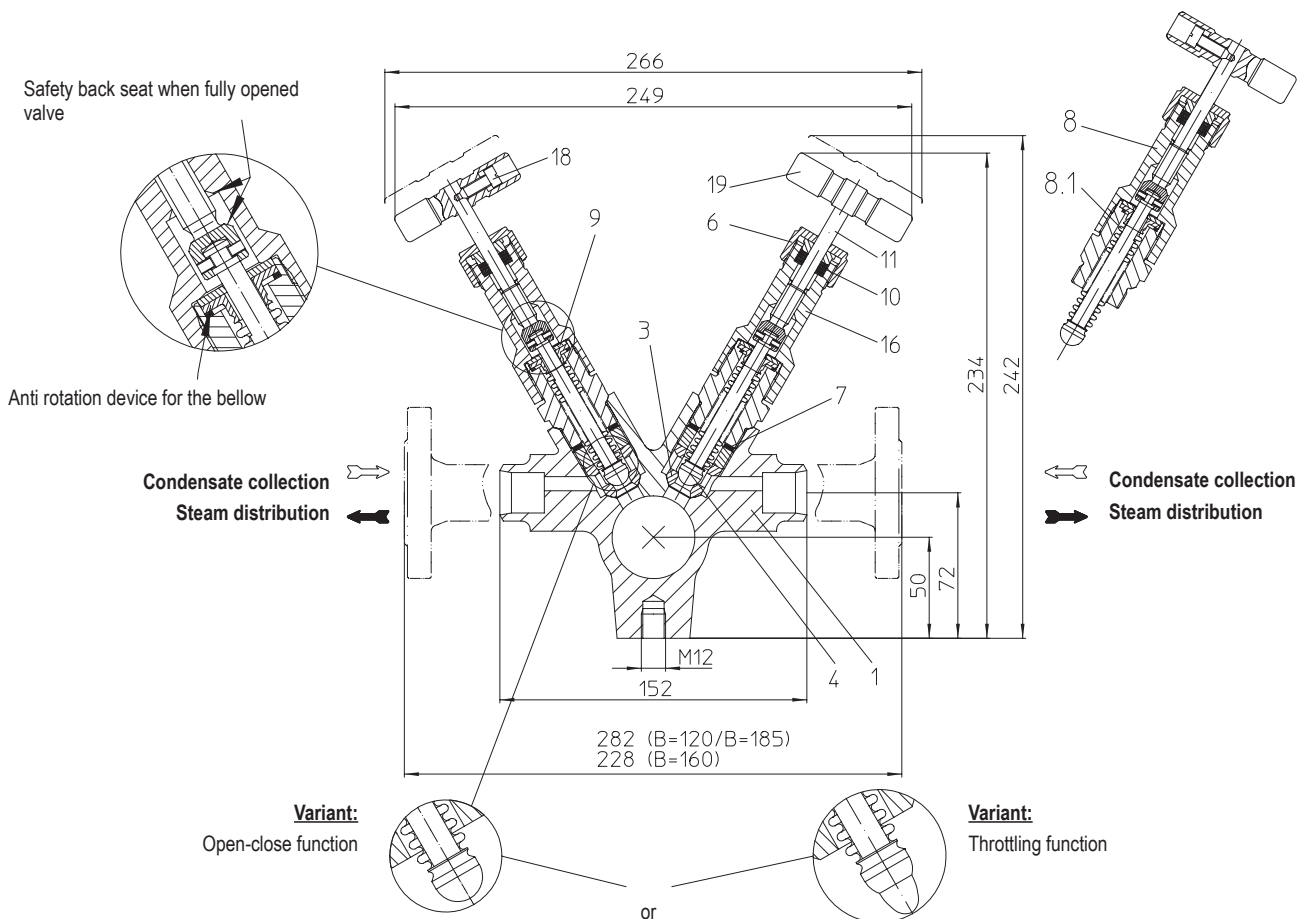
Parts				
Pos.	Sp.p.	Description	Fig. 45.675 / 45.676 Fig. 46.675 / 46.676	Fig. 55.675 / 55.676
1		Body	P250GH, 1.0460	X6CrNiTi18-10, 1.4541 or X2CrNiMo17-12-2, 1.4404
2		Connection between the modules	P325GH-TC1, 1.0305	X2CrNiMo17-12-2, 1.4404
3	x	Seat	X8CrNiS18-9, 1.4305	
4		Valve ball	X39CrMoS17+QT, 1.4122+QT	
6		Union nut	X14CrMoS17+QT, 1.4104+QT	
7		Sealing ring	Graphite	
8	x	Assembly stop valve, cpl.	X6CrNiMoTi17-12-2, 1.4571	
8.1		Bellows seal	Stainless steel	
9		Safety washer	X5CrNi18-10, 1.4301	
10	x	Packing ring	Pure graphite	
11		Stem	X2CrNiMo17-12-2, 1.4404	
16		Stem guiding	X8CrNiS18-9, 1.4305	
18	x	Cheese head screw	A2-70	
19	x	Hand grip	X14CrMoS17+QT, 1.4104+QT	
		Other interior parts	Stainless steel	
	L Spare parts			

Information / restriction of technical rules need to be observed!

Resistance and fitness must be verified (contact manufacturer for information, refer to Product overview and Resistance list).

Operating and installation instructions can be downloaded at [www.ari-armaturen.com](http://www.ari-armaturen.com).

DN		15	20	25	40	50
Length B1	B = 120 mm (mm)	81	81	81	81	81
	B = 160 mm (mm)	118	118	118	138	138

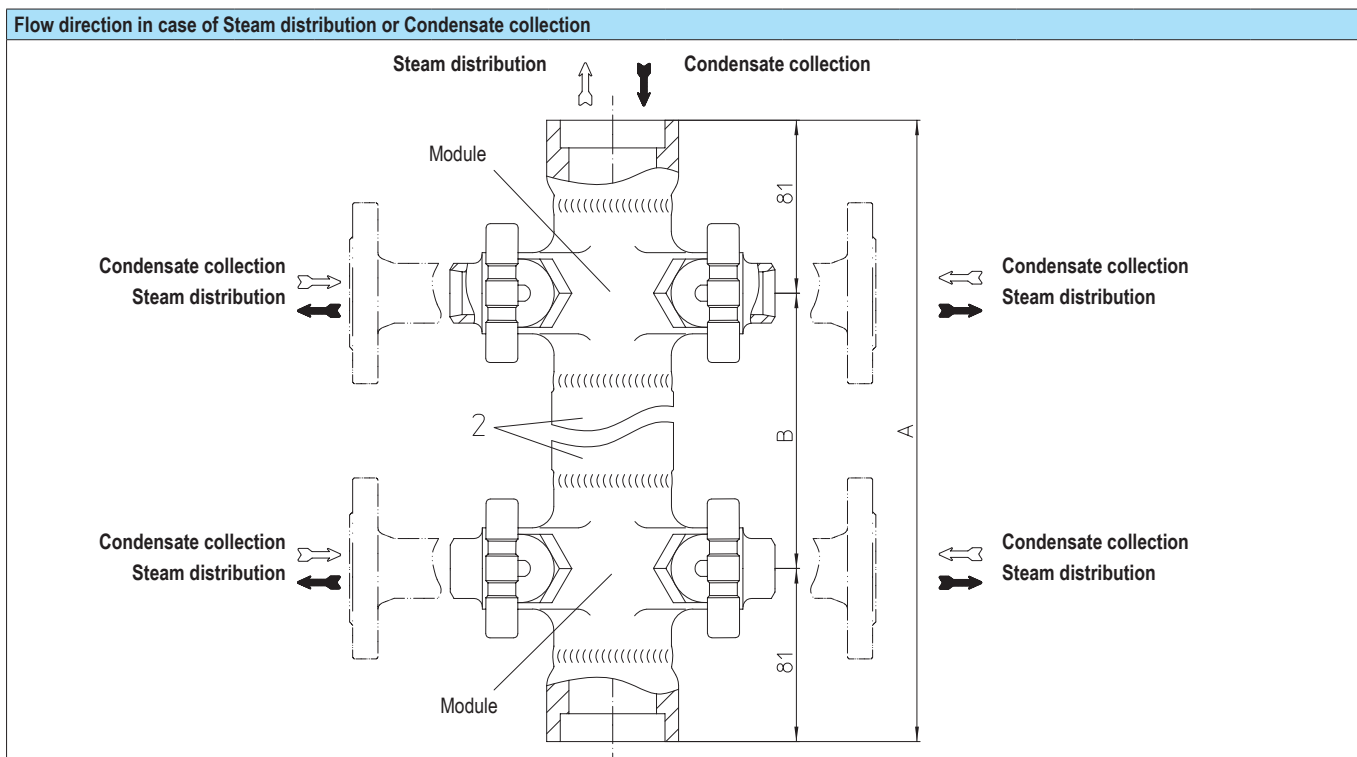

Dimensions and weights		Face-to-face acc. to data sheet resp. customer request								
Fig. 675 / 676		... -02	... -04	... -06	... -08	... -10	... -12	... -14	... -16	... -18

PN40		B = 120 mm								Standard-flange dimensions refer to page 7	
Dimension A	(mm)	162	282	402	522	642	762	882	1002	1122	
Weight (approx.)	(kg)	3,5	7,2	10,7	14,7	17,7	21,2	24,7	28,2	31,7	

PN40		B = 160 mm								Standard-flange dimensions refer to page 7	
Dimension A	(mm)	162	322	482	642	802	962	1122	1282	1442	
Weight (approx.)	(kg)	3,5	7,5	11	14,5	18	21,5	25	28,5	32	

PN63		B = 185 mm								Standard-flange dimensions refer to page 7	
Dimension A	(mm)	162	347	532	717	902	1087	1272	1457	1642	
Weight (approx.)	(kg)	4	8,5	12,5	16,5	20,5	24,5	28,5	32,5	36,5	

**Operating ranges**

Fig. 671/672 and Fig. 675/676 both can be applied as condensate collector or steam distributor. Applications are wide spread piping systems, steam tracers on pipes and apparatus. The flow media can be steam, water, oil etc. On the application as steam distributor the steam inlet is at the top flange. At the bottom outlet flange a steam trap shall be installed. On the application as condensate collector the outlet is at the top flange. At the bottom flange a blowdown valve shall be installed. In case of a vertical installation a siphon pipe should be applied. This ensures even temperature distribution thus pressure shocks and noise on condensate return are reduced..

The design is based on a robust module construction with integral stop valves (ball/seat). Body and stop valve are threaded together with a hard seal (metal to metal).

Integral stop valves on CODI S require low maintenance. All functional parts are replaceable in situ. There is no need for manifold removal from the pipe. Fig. 676 (CODI B bellows seal design for horizontal installation) and Fig. 675 (CODI B bellows seal design for vertical installation) are designed for those installations where we find the highest requirements for tight sealing to the open and maintenance free operation of the valve.

A clearance of 50 mm between the construction bracket and the condensate collector/steam distributor ensures that the insulation jacket can be wrapped around it.

During welding at the primary and secondary connections the integral stop valves have to be in an open position. Further precautions are not required..

**Handling**

The integral stop valves with shut-off plugs shall not be used for throttling of condensate or steam flows.

For throttling purposes the throttling plug shall be applied. The valves are generally equipped with back seats.

The advantage of Fig. 671/ 672 is that this additional back seat sealing protects the graphite packing and multiples it's longevity.

On Fig. 675/676 the back seat may be advantageous in case of damages to the bellows. On CODI B 675/676 no twist to the bellow will be effected due to the non-rotation lock.

The stop valves are screwed into the body without using a gasket (hard seal) If necessary, the union nut (pos. 6) can be tightened, but the stem must to be turned with normal forces!

**Basic types**

Vertical installation		recommended for attachment
Fig. 671 / 675	-02	1 screw
Fig. 671 / 675	-04	2 screws
Fig. 671 / 675	-06	3 screws
Fig. 671 / 675	-08	3 screws
Fig. 671 / 675	-10	4 screws
Fig. 671 / 675	-12	4 screws
Fig. 671 / 675	-14	5 screws
Fig. 671 / 675	-16	5 screws
Fig. 671 / 675	-18	6 screws

Horizontal installation		recommended for attachment
Fig. 672 / 676	-02	1 screw
Fig. 672 / 676	-03	2 screws
Fig. 672 / 676	-04	3 screws
Fig. 672 / 676	-05	3 screws
Fig. 672 / 676	-06	4 screws
Fig. 672 / 676	-07	4 screws
Fig. 672 / 676	-08	5 screws
Fig. 672 / 676	-09	5 screws

**Installation position Preferably vertical.**

Threaded connection M12 are provided at the back for the attachment to a supporting structure.

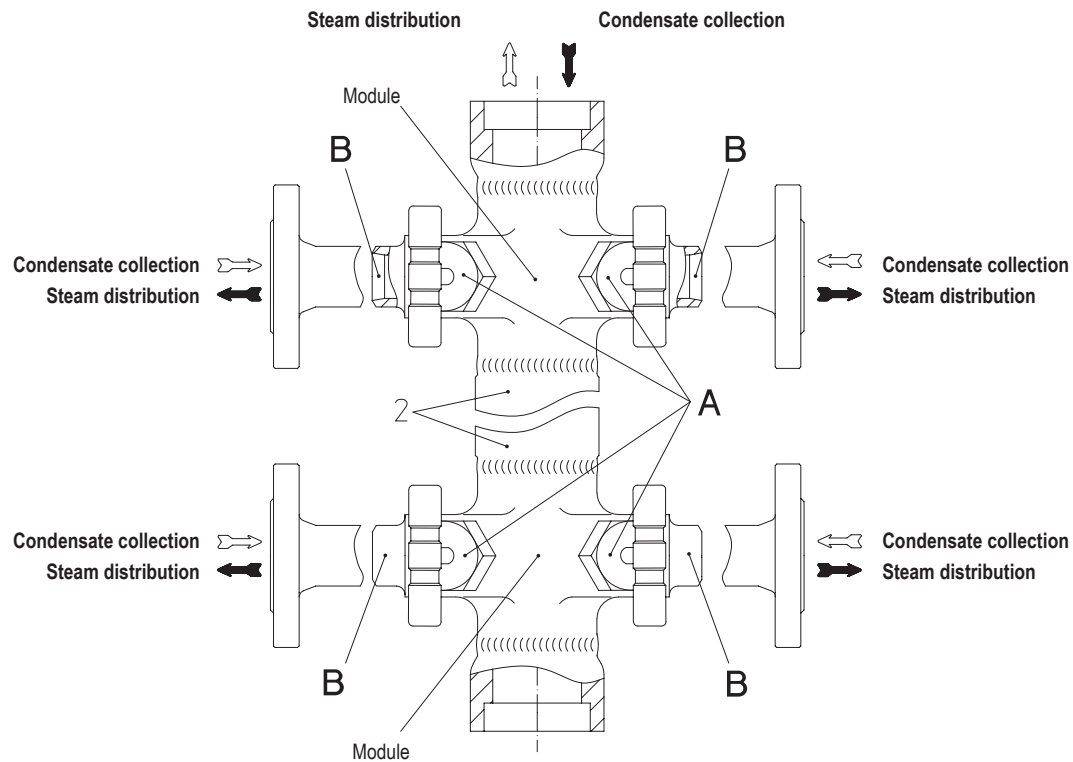
**Working principle**

<b>Condensate collection</b>	<ul style="list-style-type: none"> <li>• Condensate inlet in port B side (lateral)</li> <li>• Condensate outlet usually at the top</li> <li>• Opening and closing of the port B side with stop valves A</li> </ul>
<b>Steam distribution</b>	<ul style="list-style-type: none"> <li>• Steam inlet at the top</li> <li>• Steam outlet through port B sides (lateral)</li> <li>• Opening and closing of the port B side with stop valves A</li> </ul>

**Informations about pipe welding**
**Welding groove acc. to DIN 2559**

The material used for ARI valves with butt weld ends are:

1.0460	P250GH acc. to DIN EN 10222-2
1.4404	X2CrNiMo17-12-2, 1.4404 acc. to DIN EN 10222-5

Due to our experience, we recommend to apply an electric welding process.

Because of the different material compositions and wall thickness of the steam traps and the pipe gas welding shall not be applied. Quenching cracks and coarse grain structure may develop.

Steam traps with socket-weld ends shall only be welded by arc welding (welding process 111 acc. to DIN EN 24063).

If during the time of warranty others than the manufacturer or by the manufacturer authorized persons are interfering in the product and/or the setting, the right of claim for warranty will lapse!

Standard-flange dimensions acc. to DIN 2635 / DIN 2636 or DIN EN 1092-1			Primary connections				
			Secondary connection		25	40	50
DN			15	20			
NPS			1/2	3/4	1	1 1/2	2
PN40	ØD	(mm)	95	105	115	150	165
	ØK	(mm)	65	75	85	110	125
	n x Ød	(mm)	4 x 14	4 x 14	4 x 14	4 x 18	4 x 18
PN63	ØD	(mm)	105	130	140	170	180
	ØK	(mm)	75	90	100	125	135
	n x Ød	(mm)	4 x 14	4 x 18	4 x 18	4 x 22	4 x 22



Insulating jacket / pipe connection

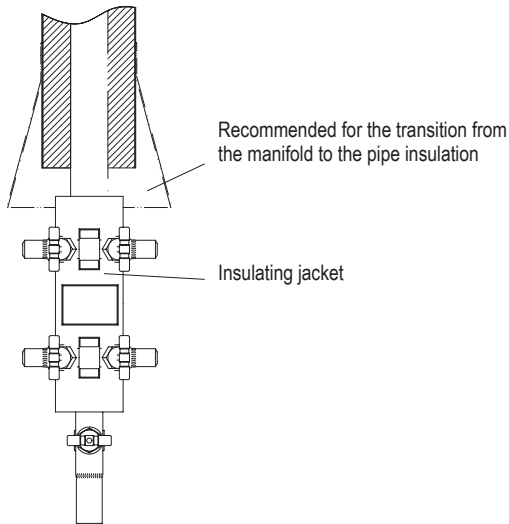

Insulating jacket in mounted position

Insulating jacket preventing radiation of heat

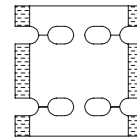

**Cona insulating jackets provide a simple and effective heat insulation (suitable for every condensate collection / steam distribution)**

**Advantages:**

- energy saving
- less radiation of heat to the atmosphere
- safety of the operation personal
- robust, non ageing
- resistance to heat
- low weight and flexible
- clean handling (no contact with the insulating material)
- free from asbestos
- water repellent
- simple disassembly and reusable

Immersion tube

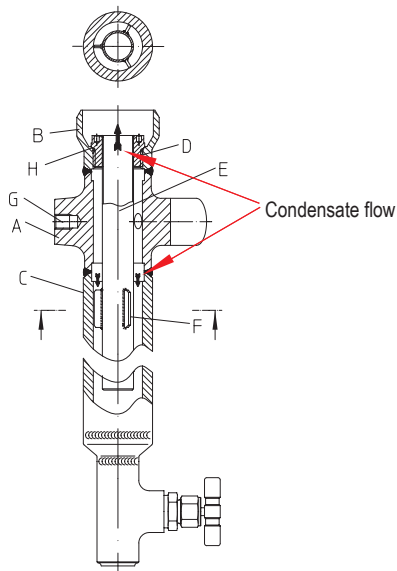

Condensate collector with immersion tube

Part	Description	
A	CODI® Module	
B	But weld end	
C	Welding bushing for the connection with an additional module	
D	Banjo bolt	X5CrNi18-10, 1.4301
E	Immersion tube	X6CrNiTi18-10, 1.4541
F	Spacer	X5CrNi18-10, 1.4301
G	Fixing point	
H	Metal-to-metal seal between banjo bolt and welding bush	

Fastening parts

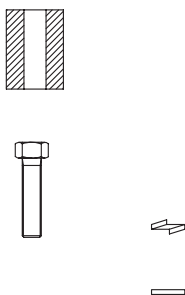

- 1 Satz consisting of:
  - Distance sleeve
  - Hexagon bolt M12
  - Washer
  - Washer



- Mounting wrench



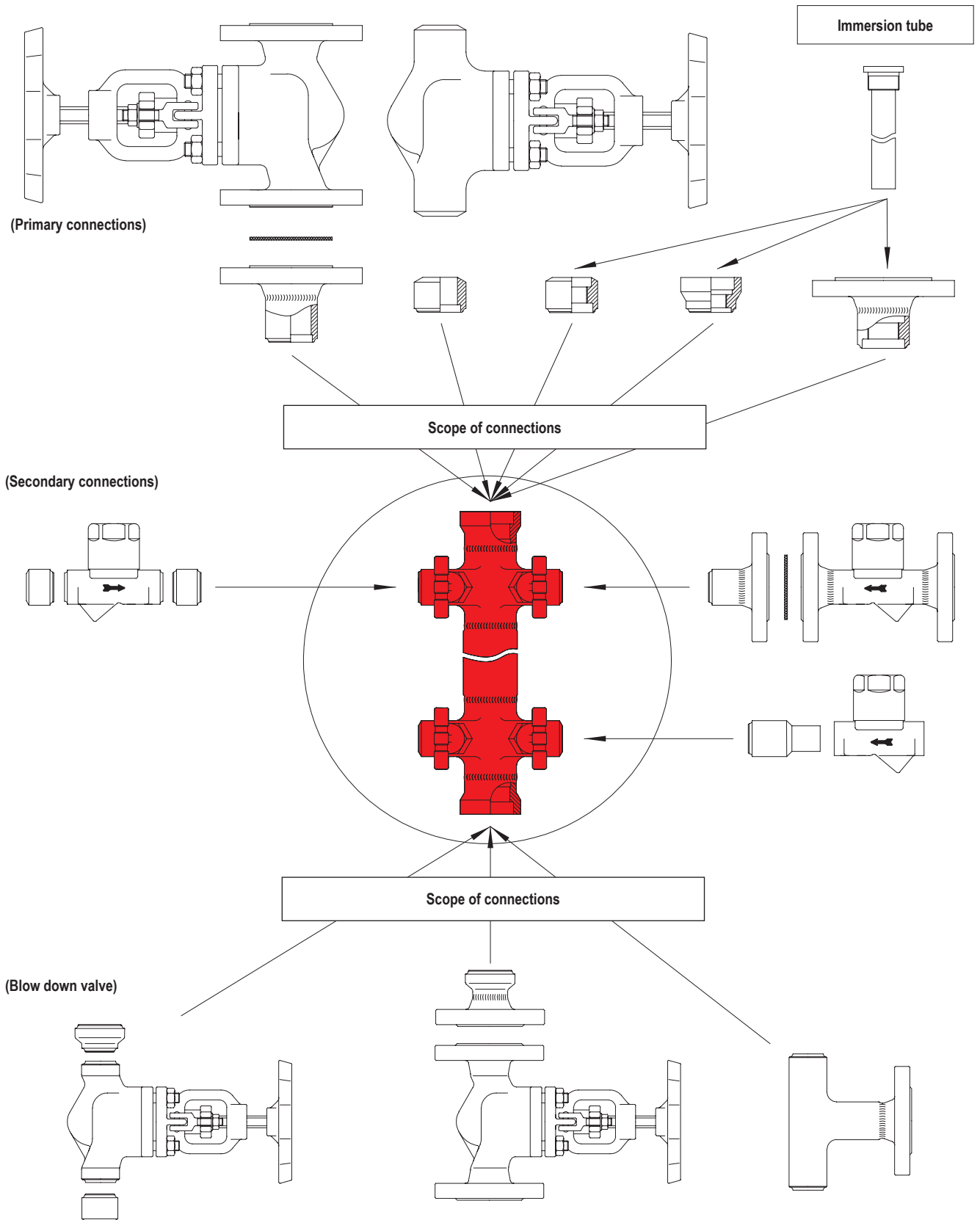

**Preferred vertical installation**

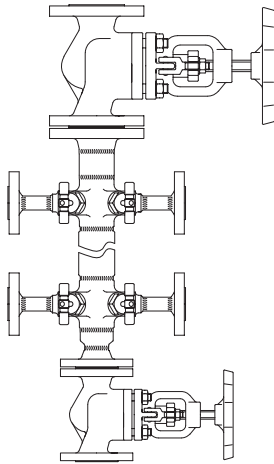

- ... **primary stop valve (flanged) for welding neck flange**  
DN 40 acc. to DIN 2635 or DN 50 acc. to DIN 2635 or DIN 2636
- ... **secondary connections (flanged)**  
DN 15 to DN 25 acc. to DIN 2635 or DIN 2637
- ... **design with blow down valve**

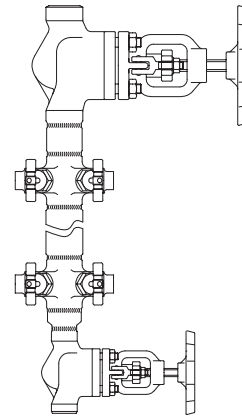

- ... **primary stop valve (butt weld ends)**  
DN 40 and DN 50 acc. to DIN EN 12627
- ... **secondary connections (butt weld ends)**  
DN 15 to DN 25 acc. to DIN EN 12627
- ... **design with blow down valve**

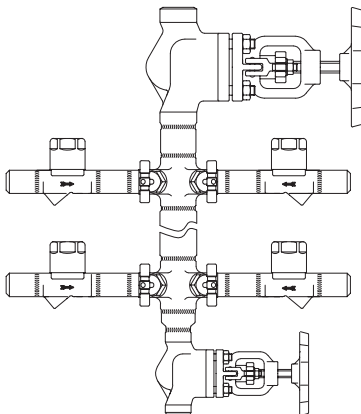

- ... **primary stop valve (butt weld ends)**  
DN 40 and DN 50 acc. to DIN EN 12627
- ... **secondary connections with steam trap (butt weld ends)**  
DN 15 to DN 25 acc. to DIN EN 12627
- ... **design with blow down valve**

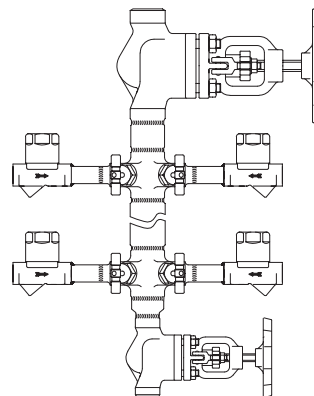

- ... **primary stop valve (butt weld ends)**  
DN 40 and DN 50 acc. to DIN EN 12627
- ... **secondary connections with steam trap (socket weld ends)**  
DN 15 to DN 25 acc. to DIN EN 12627
- ... **design with blow down valve**

**Horizontal installation**

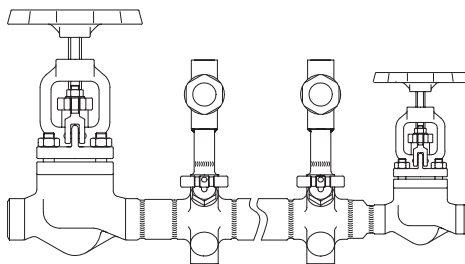

- ... **primary stop valve (butt weld ends)**  
DN 40 and DN 50 acc. to DIN EN 12627
- ... **secondary connections with steam trap (socket weld ends or butt weld ends)**  
DN 15 to DN 25 acc. to DIN EN 12760 or DN 15 to DN 25 acc. to DIN EN 12627 (butt weld ends)
- ... **design with blow down valve**

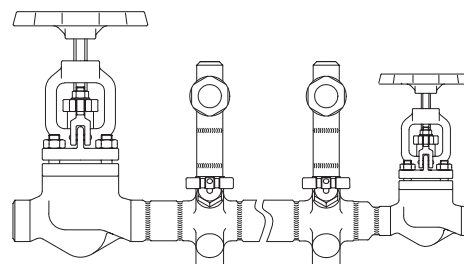

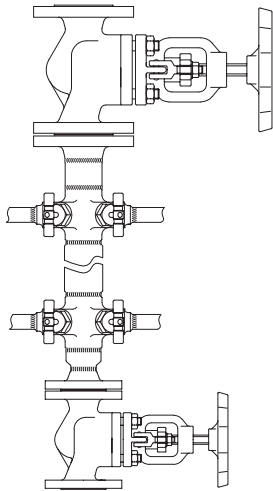

... primary stop valve and secondary connections - design with blow down valve

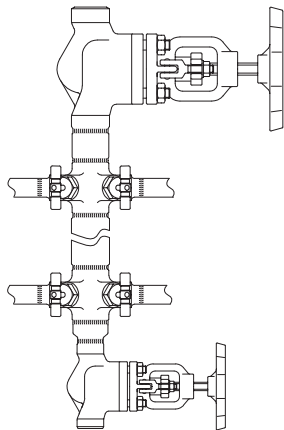

... primary stop valve and secondary connections - design with blow down valve

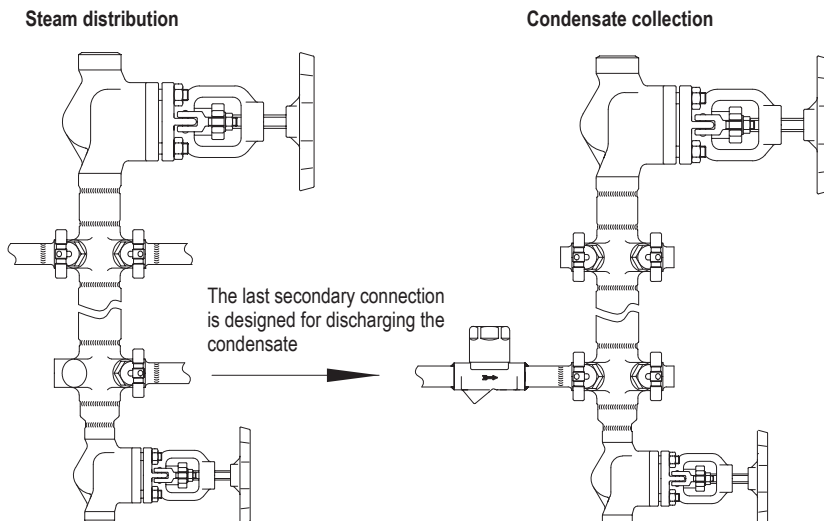

... primary stop valve and secondary connections - design with blow down valve

... steam trap at the condensate collector

Offer-No.: .....

Inquiry-No.: .....

 **Inquiry**
 **Order**

- Series:**
- CODI® S** with gland packing  Fig. 671  
 Fig. 672
- CODI® B** with bellows seal (maintenance-free)  Fig. 675  
 Fig. 676

**From:** .....

.....

.....

**Telephone:** .....

.....

**Fax:** .....

- Vertical installation**
- Fig. 671 / 675 -02  
 Fig. 671 / 675 -04  
 Fig. 671 / 675 -06  
 Fig. 671 / 675 -08  
 Fig. 671 / 675 -10  
 Fig. 671 / 675 -12  
 Fig. 671 / 675 -14  
 Fig. 671 / 675 -16  
 Fig. 671 / 675 -18
- Horizontal installation**
- Fig. 672 / 676 -02  
 Fig. 672 / 676 -03  
 Fig. 672 / 676 -04  
 Fig. 672 / 676 -05  
 Fig. 672 / 676 -06  
 Fig. 672 / 676 -07  
 Fig. 672 / 676 -08  
 Fig. 672 / 676 -09

- Types:**
- Application:**
- Condensate collection  
 Steam distribution

**Connections:**

Connection		Top Inlet- / Outlet		Bottom Inlet- / Outlet		Secondary connection	
		DIN	ANSI	DIN	ANSI	DIN	ANSI
Screwed sockets Rp							
Screwed sockets NPT							
Butt weld ends							
Socket weld ends							
Flange							
DN 15	NPS 1/2"	--	--				
DN 20	NPS 3/4"	--	--				
DN 25	NPS 1"	--	--				
DN 40	NPS 1 1/2"					--	--
DN 50	NPS 2"					--	--

- Sizing acc. to:**
- DIN PN40 - P250GH, 1.0460  ANSI 150 - SA105  ANSI 150 - SA182F321  
 DIN PN40 - X6CrNiTi18-10, 1.4541  ANSI 300 - SA105  ANSI 300 - SA182F321  
 DIN PN63 - P250GH, 1.0460

- Certification:**
- Inspection certificates acc. to DIN EN 10204 / 2.2 (Final and Material certificates)  
 Inspection certificates acc. to DIN EN 10204 / 3.1 (Final and Material certificates)

- Pressure test:**
- acc. to DIN EN 12266  acc. to API 598

- Options**
- Stop valve at the top inlet/outlet  Drainage at the bottom  
 Tracer (secondary) connection incl. steam traps **Control principle:**  
 Tracer (secondary) connection incl. return temperature control valve  Capsule  
 Bimetallic  
 Thermodynamic

- Accessories:**
- Immersion tube  
 Insulation  
 Set of fastening parts  
 Mounting wrench

- Heat transfer fluid:**
- Steam  
 Water  
 Oil  
 other .....

**Specials:** .....

**Quantity:** .....